

2018

HYDRO
polymer

HYDRO POLYMER

Polyethylene Pipe & Fittings Manufacturer Co.
Technical Catalogue



Electrofusion Fittings



Buttfusion Fittings



Flanged Joint Fittings

HYDRO Polymer Technical & Products CATALOGUE 2018

COMPANY PROFILE
Профиль Компании

1

Products
Продукты

6

TECHNICAL DATA
технические данные

50

Reference Project
заключительные слова

67



HYDRO Polymer Company is a leading manufacturer of polyethylene pipe and fittings for water and gas services, this company was established on 2007 with capacity around 1200MT/Year.

HYDRO Polymer Company will be able to produce a wide range of injection fittings in a same time due to having 17 lines which are made up in German.

This company is supply lots of products as follow:

- Electrofusion Fittings
- Butt Fusion Fittings
- Flanged Joint Fittings
- Special Fittings (according to customer request and standard requirement)

The flanged joint fittings are our specialty, and at this time we inject them up to maximum outside diameter 630mm.

This Company in order to extend its production, proceed to purchase pipeline machineries with CINCINNATI brand in which are able to produce polyethylene pipe up to size 630mm .

Training



Nero held up some courses for customers in both theory and practical use for those who will work in pipeline construction.

Topics covered include:

- The properties of polyethylene
- Production, characteristics and classifications of pipes and fittings
- Welding techniques (Butt fusion and Electrofusion)
- Maintenance



Marking



Producer identification

PN	Nominal pressure
SDR	Standard dimension ratio
d	Nominal size of the fitting (mm)
PE 100	Raw material type used
INSO..., ISO..., EN....	Product standard

HYDRO Polymer fittings have the following information stated on the fittings and/or on a label.

The barcode label is applied on the electrofusion fittings contain the welding parameter according to standard ISO 13950 and the traceability data of the fitting according to standard ISO 12176-4

Quality Control & Laboratory

Quality Control & Laboratory:

HYDRO Polymer fittings are continuously monitored throughout the entire production process in accordance with the internal testing programs in compliance with the standards EN 1555, EN 12201, ISO 4427 and INSO 14427. The testing activities are continuously carried out following up the complete observance of the reference standards and foresee tests of mechanical and physical type, either on the fittings and on the raw material.

Particularly, the production is subjected to the following tests:

Dimensional Control, Marking control

Ref. EN 1555, EN 12201, ISO 4427, INSO 14427

Carbon Black Content

Ref. ISO 6964

Hydrostatic Strength at 20°C and 80°C

Ref. ISO 1167

Decohesive resistance (peel and crushing test)

Ref. ISO 13954, ISO 13955, ISO 13956

Oxidation Induction Time (OIT)

Ref. ISO 11357-6

Density

Ref. ISO 1183

Carbon Black Dispersion

Ref. ISO 18553

Elongation at break

Ref. ISO 6259 -1 & 3

Longitudinal

Ref. ISO 2505

Melt mass-flow rate (MFR)

Ref. ISO 1133-1, 2





PRODUCTS

Overview

Electrofusion fittings	page
Tapping Saddle with 360° rotatable outlet	11
Coupler	12
Electrofusion assembly	13
Buttfusion fittings	
Flange	19
Equal Tee	21
Reduced Tee	22
Elbow 90°	23
Elbow 45°	24
Fabricated Elbow 11.25° & 22.5° & 30	25
Reducer	26
Cap	29
Cross 90°	30
Flanged Joint Fittings	
Steel Core Hole Flange	31
Flat face Equal Tee	32
Flat face Reduced Tee	33
Flat face Elbow	34
Flat face Cap	35
Mitering fittings and Special fittings	
Fabricated Elbow	36
Fabricated Equal Tee	38
Branched Reduced Tee	39
Gasket	45
Transition Fitting	46
Collector	47
Backing Rings	
PP/Steel Backing Ring	42
Backing Ring	43
Welding Machine	
Electrofusion Welding machine	48
Butt Welding machines	49



Polyethylene Pipe Specification DIN 8074, INSO 14427

SDR	51		41		33		26		22		21		17.6		17		13.6		11		9		7.4		6		5	
	S	W	S	W	S	W	S	W	S	W	S	W	S	W	S	W	S	W	S	W	S	W	S	W	S	W	S	W
PE 80 SF 1.25	2.5		3.2		4.0		5.0		6.0		6.4(6.0)		7.4		8.0		10.0		12.5		16.0		20.0		25.0		32.0	
PE 80 SF 1.6	2.0		2.5		3.0		4.0		4.6		5.0		6.0		6.3		8.0		10.0		12.5		16.0		20.0		25.0	
PE 80 SF 2	1.6		2.0		2.5		3.0		3.8		4.0		4.8		5.0		6.3		8.0		10.0		12.5		16.0		20.0	
PE 100 SF 1.25	3.2		4.0		5.0		6.3(6.0)		7.4		8.0		9.6		10.0		12.5		16.0		20.0		25.0		32.0		40.0	
PE 100 SF 1.6	2.5		3.0		4.0		5.0		6.0		6.3		7.4		8.0		10.0		12.5		16.0		20.0		25.0		31.0	
PE 100 SF 2	2.0		2.5		3.0		4.0		4.8		5.0		6.0		6.3		8.0		10.0		12.5		15.5		20.0		25.0	
Diameter (mm)	S	W	S	W	S	W	S	W	S	W	S	W	S	W	S	W	S	W	S	W	S	W	S	W	S	W	S	W
20																												
25																												
32																												
40																												
50																												
63																												
75	1.8	0.44	2	0.462	2.3	0.557	2.9	0.683	3.5	0.816	3.6	0.836	4.3	0.987	4.5	1.03	5.6	1.25	6.8	1.48	8.4	1.78	10.3	2.12	12.5	2.47	15.1	2.85
90	2	0.531	2.2	0.647	2.8	0.8	3.5	0.988	4.1	1.15	4.3	1.2	5.1	1.4	5.4	1.47	6.7	1.79	8.2	2.14	10.1	2.57	12.3	3.03	15	3.54	18.1	4.09
110	2.2	0.795	2.7	0.952	3.4	1.19	4.2	1.45	5.0	1.69	5.3	1.79	6.3	2.1	6.6	2.19	8.1	2.64	10.0	3.18	12.3	3.82	15.1	4.54	18.3	5.29	22.1	6.1
125	2.5	1.01	3.1	1.25	3.9	1.53	4.8	1.86	5.7	2.19	6.0	2.29	7.1	2.69	7.4	2.79	9.2	3.4	11.4	4.12	14.0	4.92	17.1	5.84	20.8	6.82	25.1	7.87
140	2.8	1.26	3.5	1.56	4.3	1.9	5.4	2.35	6.4	2.75	6.7	2.86	8.0	3.37	8.3	3.5	10.3	4.26	12.7	5.13	15.7	6.18	19.2	7.33	23.3	8.56	28.1	9.87
160	3.2	1.65	4.0	2.02	4.9	2.45	6.2	3.08	7.3	3.58	7.7	3.75	9.1	4.4	9.5	4.57	11.8	5.56	14.6	6.74	17.9	8.04	21.9	9.54	26.6	11.2	32.1	12.9
180	3.6	2.07	4.4	2.51	5.5	3.1	6.9	3.83	8.2	4.52	8.6	4.71	10.2	5.54	10.7	5.77	13.3	7.05	16.4	8.51	20.1	10.2	24.6	12.1	29.9	14.1	36.1	16.3
200	3.9	2.48	4.9	3.08	6.2	3.88	7.7	4.74	9.1	5.57	9.6	5.84	11.4	6.86	11.9	7.12	14.7	8.65	18.2	10.5	22.4	12.6	27.4	14.9	33.2	17.4	40.1	20.1
225	4.4	3.16	5.5	3.9	6.9	4.82	8.6	5.96	10.3	7.07	10.8	7.37	12.8	8.64	13.4	9.03	16.6	11	20.5	13.3	25.2	15.9	30.8	18.8	37.4	22.1	45.1	25.4
250	4.9	3.88	6.2	4.88	7.7	5.98	9.6	7.38	11.4	8.68	11.9	9.02	14.2	10.7	14.8	11.1	18.4	13.5	22.7	16.3	27.9	19.6	34.2	23.3	41.5	27.2	50.1	31.4
280	5.5	4.88	6.9	6.04	8.6	7.47	10.7	9.2	12.8	10.9	13.4	11.4	15.9	13.3	16.6	13.9	20.6	16.9	25.4	20.5	31.3	24.6	38.3	29.9	46.5	34.1	56.2	39.4
315	6.2	6.18	7.7	7.59	9.7	9.47	12.1	11.7	14.4	13.8	15.0	14.3	17.9	16.9	18.7	17.6	23.2	21.5	28.6	25.9	35.2	31.3	43.1	36.9	52.3	43.2	63.2	49.8
355	7.0	7.81	8.7	9.65	10.9	12	13.6	14.8	16.2	17.5	16.9	18.2	20.1	21.4	21.1	22.4	26.1	27.2	32.2	32.9	39.7	39.5	48.5	46.8	59.0	54.8	-	-
400	7.9	9.92	9.8	12.2	12.3	15.2	15.3	18.8	18.2	22.1	19.1	23.1	22.7	27.2	23.7	28.3	29.4	34.5	36.3	41.7	44.7	50.1	54.7	59.4	66.5	69.6	-	-
450	8.8	12.4	11.0	15.4	13.8	19.2	17.2	23.7	20.5	28	21.5	29.3	26.7	34.3	26.7	35.8	33.1	43.7	40.9	52.8	50.3	63.4	61.5	75.2	-	-	-	-
500	9.8	15.4	12.3	19.2	15.3	23.6	19.1	29.2	22.8	34.5	23.9	36.1	28.3	42.3	29.7	44.2	36.8	53.9	45.4	65.2	55.8	78.1	68.3	92.8	-	-	-	-
560	11.0	19.3	13.7	23.9	17.2	29.7	21.4	36.6	25.5	43.2	26.7	45.2	31.7	53	33.2	55.4	41.2	67.6	50.8	81.7	62.5	98	-	-	-	-	-	-
630	12.3	24.3	15.4	30.2	19.3	37.5	24.1	46.4	28.7	54.7	30.0	57	35.7	67.2	37.4	70.2	46.3	85.5	57.2	103	-	-	-	-	-	-	-	-

Data: T= 20° C and 50 years of service life, SDR: Standard Dimensional Ratio, SF: Safety Factor, PN: Nominal Pressure (bar), S: Thickness (mm), W: Weight in kg/m, (INSO 14427)

HDPE 100

Tapping saddle with 360° Rotatable outlet
Электросварные Отводы

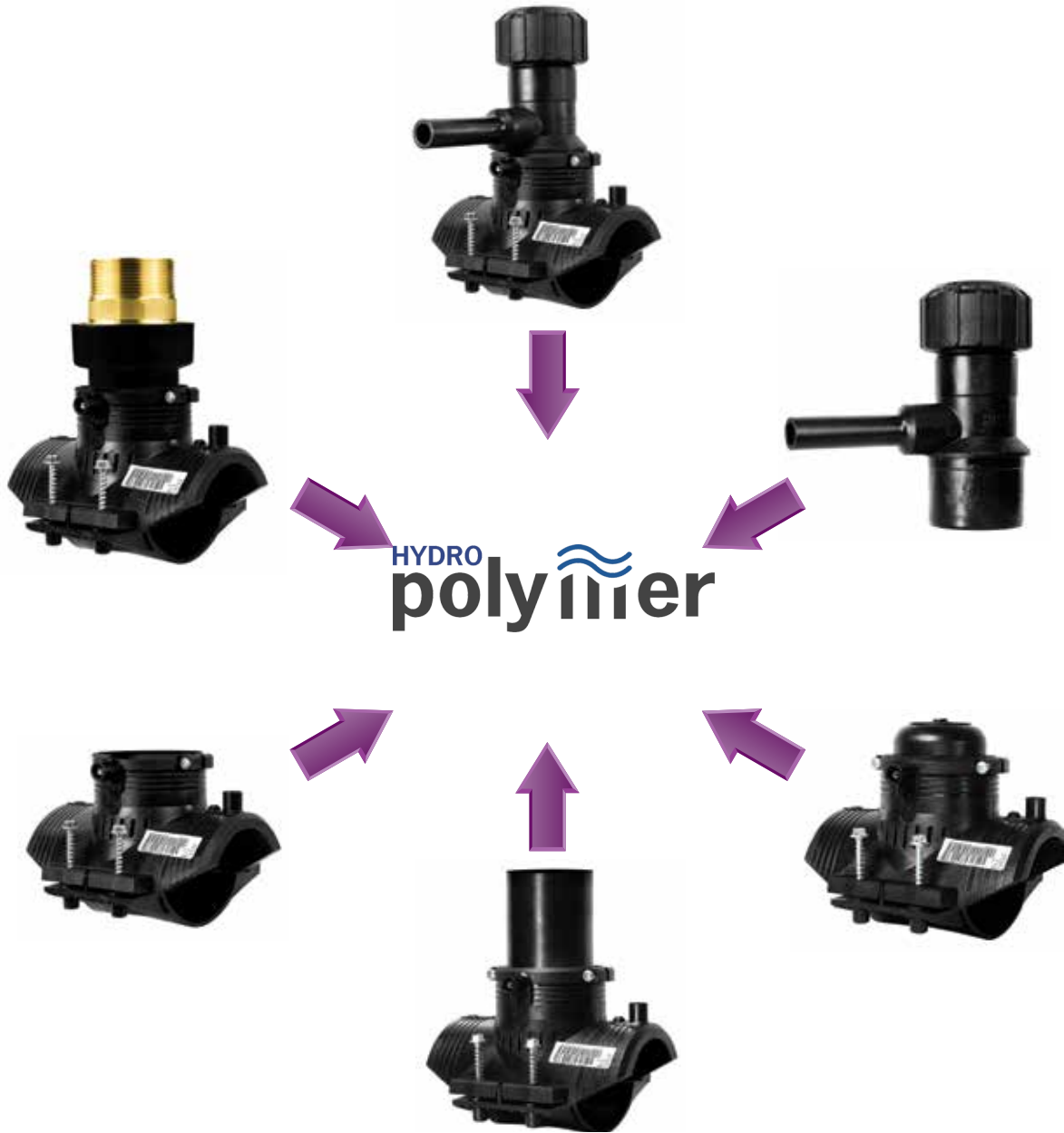

Tapping saddle with 360° Rotatable outlet

HDPE 100

Электросварные Отводы

Nominal size (mm)	Code	d2 (mm)	H (mm)	H1 (mm)	L (mm)	L1 (mm)	Z (mm)
63×25	SD1C0602	32	186	108	165	71	130
63×32	SD1C0603	32	186	108	165	76	130
63×40	SD1C0604	32	186	108	165	81	137
63×50	SD1C0605	32	186	108	165	86	137
63×63	SD1C0606	32	134	112	165	100	160
90×25	SD1C0802	32	199	121	165	71	130
90×32	SD1C0803	32	199	121	165	76	130
90×40	SD1C0804	32	199	121	165	81	137
90×50	SD1C0805	32	199	121	165	86	137
90×63	SD1C0806	32	248	126	165	100	160
110×25	SD1C0902	32	209	131	165	71	130
110×32	SD1C0903	32	209	131	165	76	130
110×40	SD1C0904	32	209	131	165	81	137
110×50	SD1C0905	32	209	131	165	86	137
110×63	SD1C0906	35	258	136	165	100	160
160×25	SD1C1202	32	243	156	165	71	130
160×32	SD1C1203	32	243	156	165	76	130
160×40	SD1C1204	32	243	156	165	81	137
160×50	SD1C1205	32	243	156	165	86	137
160×63	SD1C1206	35	283	161	165	100	160
200×25	SD1C1402	32	254	176	165	71	130
200×32	SD1C1403	32	254	176	165	76	130
200×40	SD1C1404	32	254	176	165	81	137
200×50	SD1C1405	32	254	176	165	86	137
200×63	SD1C1406	35	303	181	165	100	160
* 250×25	SD1C1602	32	279	201	165	76	130
* 250×32	SD1C1603	32	279	201	165	76	130
* 250×40	SD1C1604	32	279	201	165	81	137
* 250×50	SD1C1605	32	279	201	165	86	137
* 250×63	SD1C1606	35	328	206	165	100	160

* Future Products

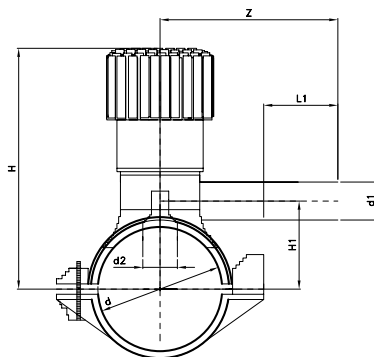
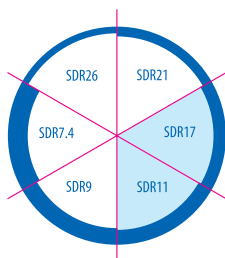

HDPE 100

Electrofusion Coupler Электросварные Муфты

Nominal size (dn) (mm)	Code	L (mm)	f (mm)	Z (mm)
*20	CU1C01	41	10	82
*25	CU1C02	41	10	82
*32	CU1C03	44	10	88
*40	CU1C04	49	10	98
*50	CU1C05	55	10	110
63	CU1C06	47	17	95
75	CU1C07	52	21	106
90	CU1C08	61	26	123
110	CU1C09	71	36	144
125	CU1C10	78	39	157
160	CU1C12	88	51	177
200	CU1C14	100	59	204
225	CU1C15	110	72	221
250	CU1C16	115	60	233
315	CU1C18	130	67	262
*355	CU1C19	164	42	328
*400	CU1C20	179	47	358

• SDR 26, SDR 21, SDR 9 and SDR 7.4 are produced according to customer order

* Future Products

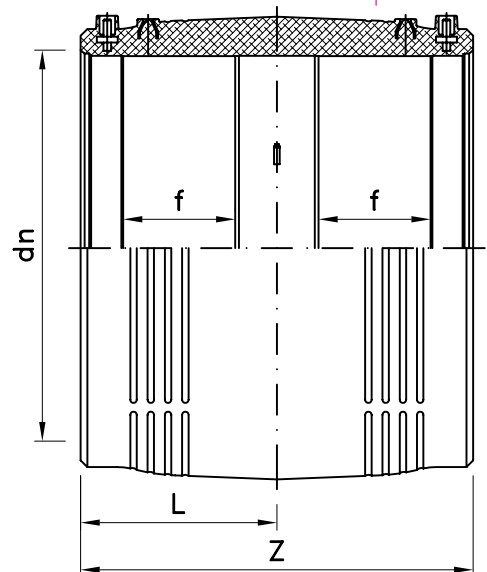
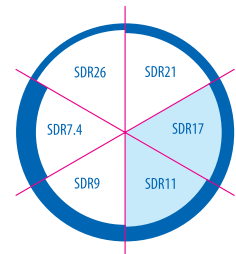

Electrofusion Equal Tee 90°

HDPE 100 Электросварные Равные Тройники 90°

Nominal size (mm)	Code	Z (mm)	Z1 (mm)	L1 (mm)	L (mm)
63	EF1C06	313	115	66	47
75	EF1C07	350	129	71	52
90	EF1C08	393	143	70	61
110	EF1C09	460	167	85	71
125	EF1C10	491	168	90	78
160	EF1C12	576	200	101	88
200	EF1C14	648	239	108	100
225	EF1C15	674	262	102	110
250	EF1C16	747	282	100	115
315	EF1C18	855	323	92	130

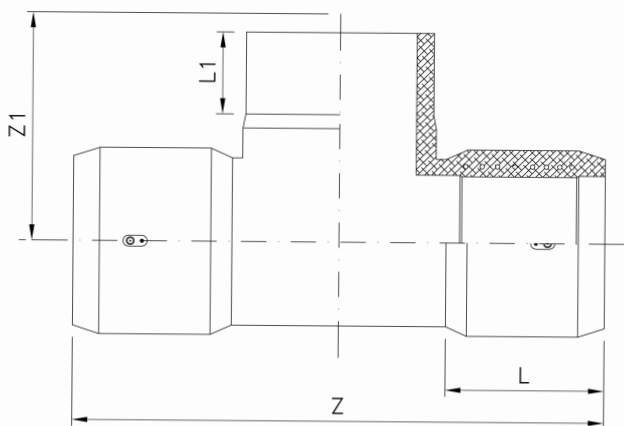
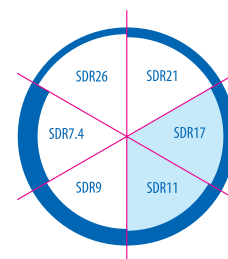

HDPE 100 Electrofusion Reduced Tee 90°

Электросварные Равные Тройники 90°

Nominal size (mm)	Code	Z (mm)	Z1 (mm)	L1 (mm)	L (mm)
75×63	EF2C0706	354	126	66	52
90×63	EF2C0806	393	133	67	61
90×75	EF2C0807	389	128	70	61
110×63	EF2C0906	460	168	66	71
110×75	EF2C0907	462	159	72	71
110×90	EF2C0908	460	155	80	71
125×63	EF2C1006	492	166	66	78
125×75	EF2C1007	491	167	71	78
125×90	EF2C1008	488	163	81	78
125×110	EF2C1009	496	168	86	78
160×63	EF2C1206	580	197	67	88
160×75	EF2C1207	576	195	75	88
160×90	EF2C1208	574	201	83	88
160×110	EF2C1209	581	204	88	88
200×63	EF2C1406	640	220	72	100
200×75	EF2C1407	640	220	72	100
200×90	EF2C1408	648	228	83	100
200×110	EF2C1409	635	215	79	100
200×160	EF2C1412	650	214	90	100
250×90	EF2C1608	745	267	79	115
250×110	EF2C1609	745	270	87	115
250×125	EF2C1610	745	268	95	115
250×160	EF2C1612	745	270	103	115
250×200	EF2C1614	745	268	101	115
315×90	EF2C1808	855	296	92	130
315×110	EF2C1809	855	296	92	130
315×125	EF2C1810	855	296	92	130
315×160	EF2C1812	840	289	87	130
315×200	EF2C1814	850	301	95	130
315×250	EF2C1816	845	296	103	130

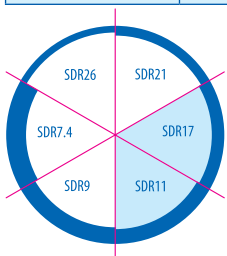
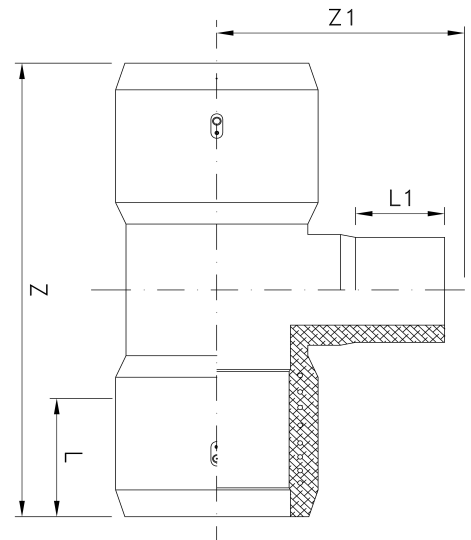

HDPE 100

Electrofusion Elbow 90° Электросварные Угольники 90°

Nominal size (mm)	Code	Z (mm)	L (mm)
63	EF3C06	159	47
75	EF3C07	172	52
90	EF3C08	188	61
110	EF3C09	224	71
125	EF3C10	250	78
160	EF3C12	288	88
200	EF3C14	348	100
225	EF3C15	353	110
250	EF3C16	365	115
315	EF3C18	459	130

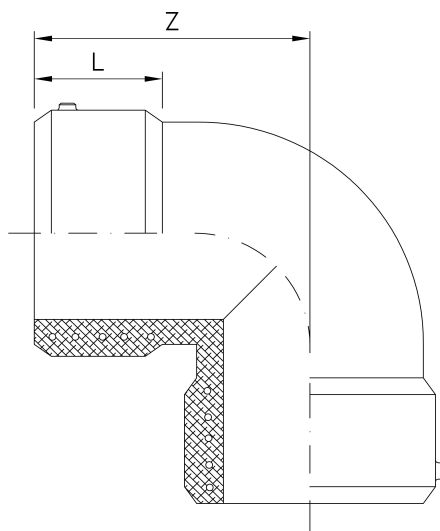
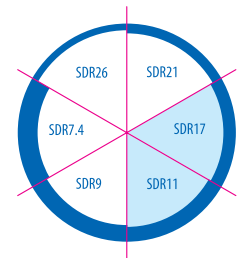

Nominal size (mm)	Code	Z (mm)	L (mm)
63	EF4C06	141	47
75	EF4C07	157	52
90	EF4C08	181	61
110	EF4C09	192	71
125	EF4C10	208	78
160	EF4C12	236	88
200	EF4C14	280	100
225	EF4C15	294	110
250	EF4C16	325	115
315	EF4C18	336	130

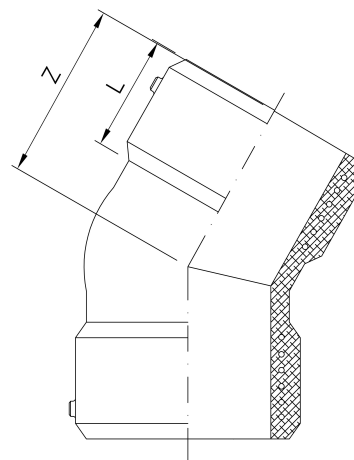
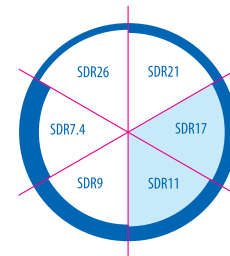

HDPE 100

Electrofusion Reducer Электросварные Переходники

Nominal size (mm)	Code	Lt (mm)	L1 (mm)	L2 (mm)
75*63	EF5C0706	243	47	52
90*63	EF5C0806	247	47	61
90*75	EF5C0807	265	52	61
110*63	EF5C0906	286	47	71
110*75	EF5C0907	290	52	71
110*90	EF5C0908	299	61	71
125*90	EF5C1008	349	61	78
125*110	EF5C1009	300	71	78
160*90	EF5C1208	361	61	88
160*110	EF5C1209	386	71	88
160*125	EF5C1210	381	78	88
200*110	EF5C1409	419	71	100
200*160	EF5C1412	471	88	100
250*110	EF5C1609	471	71	115
250*160	EF5C1612	497	88	115
250*200	EF5C1614	502	100	115

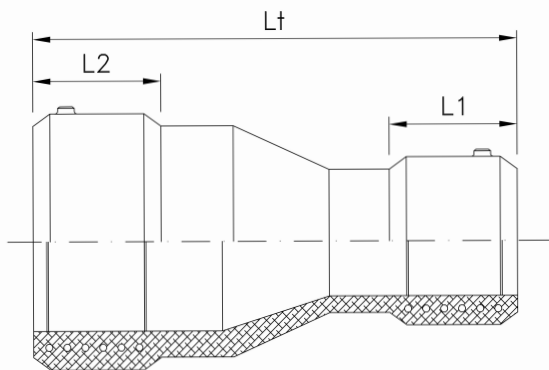
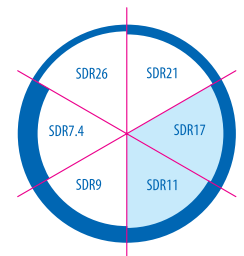

Nominal size (mm)	Code	Z (mm)	L (mm)
63	EF6C06	112	47
75	EF6C07	130	52
90	EF6C08	149	61
110	EF6C09	162	71
125	EF6C10	178	78
160	EF6C12	210	88
200	EF6C14	235	100

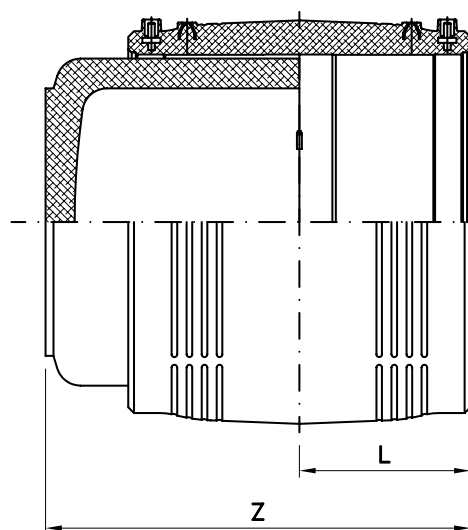
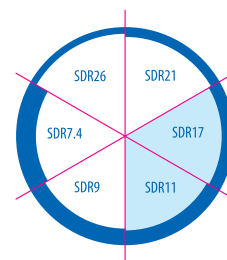

Nominal size (mm)	Code		h1 (mm)		d2 (mm)	d3 (mm)	Z (mm)	
	Normal	Long	PN10	PN16			Normal	Long
40	FL1C04	FL3C04	11	11	78	50	81	85
50	FL1C05	FL3C05	12	12	88	75	83	85
63	FL1C06	FL3C06	14	14	102	75	92	95
75	FL1C07	FL3C07	16	16	122	89	111	125
90	FL1C08	FL3C08	17	17	138	105	120	140
110	FL1C09	FL3C09	18	18	158	125	127	160
125	FL1C10	FL3C10	18	25	158	132	121	170
140	FL1C11	FL3C11	18	25	188	155	153	200
160	FL1C12	FL3C12	18	25	212	175	164	200
180	FL1C13	FL3C13	20	30	212	180	171	200
200	FL1C14	FL3C14	24	32	268	232	180	200
225	FL1C15	FL3C15	24	32	268	235	193	200
250	FL1C16	-	25	35	320	285	200	-
280	FL1C17	-	25	35	320	291	200	-
315	FL1C18	-	25	35	370	335	222	-
355	FL1C19	-	30	40	430	373	178	-
400	FL1C20	-	33	46	482	427	154	-
450	FL1C21	-	46	60	585	514	160	-
500	FL1C22	-	46	60	585	530	170	-
560	FL1C23	-	50	60	685	615	178	-
630	FL1C24	-	50	60	685	642	154	-
710	FL1C25	-	50	-	800	730	300	-
800	FL1C26	-	52	-	900	840	300	-
900	FL1C27	-	55	-	1005	944	300	-
1000	FL1C28	-	60	-	1110	1047	300	-

• Could be weld with electrofusion coupler
Type A: Without chamfer suitable for flanged connection .

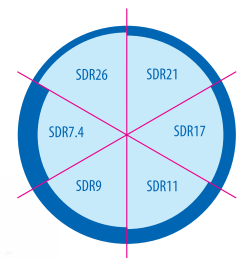
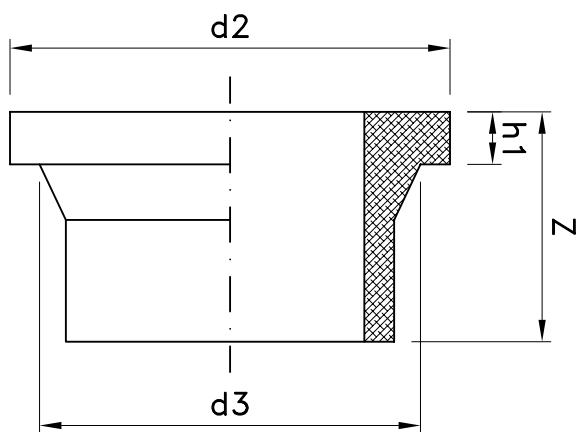

Nominal size (mm)	Code		h1 (mm)		d2 (mm)	d3 (mm)	d4 (mm)	Z (mm)	
	Normal	Long	PN10	PN16				Normal	Long
40	FL2C04	FL4C04	11	11	78	50	-	81	85
50	FL2C05	FL4C05	12	12	88	75	-	83	85
63	FL2C06	FL4C06	14	14	102	75	-	92	95
75	FL2C07	FL4C07	16	16	122	89	66	111	125
90	FL2C08	FL4C08	17	17	138	105	78	120	140
110	FL2C09	FL4C09	18	18	158	125	100	127	160
125	FL2C10	FL4C10	18	25	158	132	114	121	170
140	FL2C11	FL4C11	18	25	188	155	127	153	200
160	FL2C12	FL4C12	18	25	212	175	151	164	200
180	FL2C13	FL4C13	20	30	212	180	158	171	200
200	FL2C14	FL4C14	24	32	268	232	203	180	200
225	FL2C15	FL4C15	24	32	268	235	210	193	200
250	FL2C16	-	25	35	320	285	245	200	-
280	FL2C17	-	25	35	320	291	265	200	-
315	FL2C18	-	25	35	370	335	300	222	-
355	FL2C19	-	30	40	430	373	340	178	-
400	FL2C20	-	33	46	482	427	385	154	-
450	FL2C21	-	46	60	585	514	400	160	-
500	FL2C22	-	46	60	585	530	440	170	-
560	FL2C23	-	50	60	685	615	490	178	-
630	FL2C24	-	50	60	685	642	545	154	-
710	FL2C25	-	50	-	800	730	-	300	-
800	FL2C26	-	52	-	900	840	-	300	-
900	FL2C27	-	55	-	1005	944	-	300	-
1000	FL2C28	-	60	-	1110	1047	-	300	-

- Could be weld with electrofusion coupler
- Type B:** With chamfer suitable for butterfly valve .

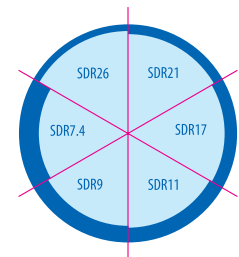
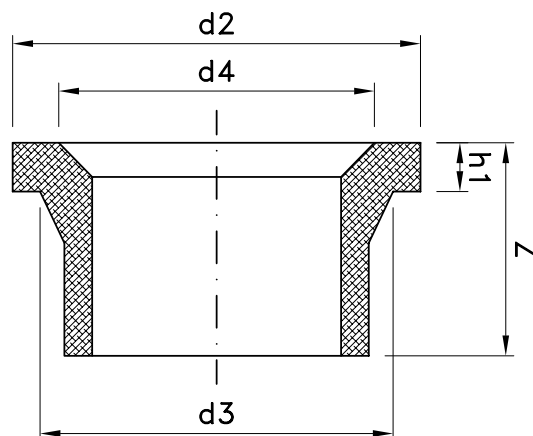

Nominal size (dn) (mm)	Code	Z (mm)	Z1 (mm)	L (mm)
*20	TE1C01	143	74	41
*25	TE1C02	158	78	41
32	TE1C03	166	82	45
40	TE1C04	188	96	50
50	TE1C05	210	107	50.5
63	TE1C06	219	115	66
75	TE1C07	246	129	71
90	TE1C08	271	143	70
110	TE1C09	318	167	85
125	TE1C10	335	168	90
*140	TE1C11	393	192	92
160	TE1C12	400	200	101
180	TE1C13	465	233	106
200	TE1C14	448	239	108
225	TE1C15	454	262	102
250	TE1C16	517	282	100
280	TE1C17	600	323	94
315	TE1C18	595	298	92
355	TE1C19	650	325	121
400	TE1C20	645	325	100
450	TE1C21	970	510	200
500	TE1C22	970	510	200

● Producing up to size 315 mm with SDR 9 and SDR 7.4
* Future Products

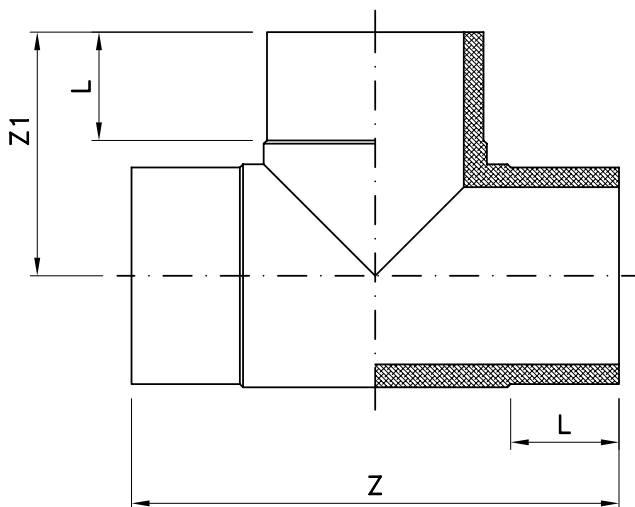

Nominal size (mm)	Code	L1 (mm)	L2 (mm)	Z1 (mm)	Z2 (mm)
63×40	TE4C0604	66	49	217	105
63×50	TE4C0605	67	63	220	109
75×40	TE4C0704	72	50	249	119
75×50	TE4C0705	71	63	246	121
75×63	TE4C0706	72	66	250	126
90×63	TE4C0806	71	67	271	133
90×75	TE4C0807	69	70	267	128
110×63	TE4C0906	87	66	318	168
110×75	TE4C0907	81	72	320	159
110×90	TE4C0908	86	80	318	155
125×63	TE4C1006	89	66	336	166
125×75	TE4C1007	89	71	337	167
125×90	TE4C1008	89	81	332	163
125×110	TE4C1009	90	86	340	168
160×63	TE4C1206	102	67	404	197
160×75	TE4C1207	98	75	400	195
160×90	TE4C1208	101	83	398	201
160×110	TE4C1209	102	88	405	204
200×63	TE4C1406	116	72	440	220
200×75	TE4C1407	115	72	440	220
200×90	TE4C1408	117	83	448	228
200×110	TE4C1409	104	79	435	215

Nominal size (mm)	Code	L1 (mm)	L2 (mm)	Z1 (mm)	Z2 (mm)
200×160	TE4C1412	116	90	450	214
250×90	TE4C1608	103	79	515	267
250×110	TE4C1609	102	87	515	270
250×125	TE4C1610	101	95	515	268
250×160	TE4C1612	102	103	515	270
250×200	TE4C1614	100	101	515	268
315×90	TE4C1608	92	92	595	296
315×110	TE4C1809	92	92	595	296
315×125	TE4C1810	92	92	595	296
315×160	TE4C1812	87	87	580	289
315×200	TE4C1814	91	95	590	301
315×250	TE4C1816	91	103	585	296
355×110	TE4C1909	118	87	640	290
355×160	TE4C1912	118	102	640	307
355×200	TE4C1914	119	119	644	332
355×250	TE4C1916	120	113	645	324
400×160	TE4C2012	98	100	645	335
400×200	TE4C2014	99	102	643	337
400×250	TE4C2016	98	100	650	330

● Producing up to size 315mm with SDR9 and SDR 7.4
- Other branches with make by Reducer.

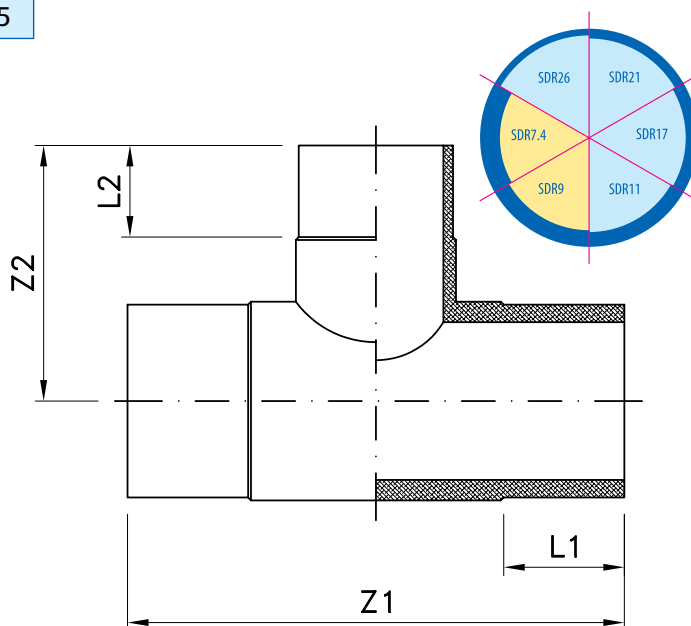

Nominal size (mm)	Code	Z (mm)	L (mm)
*20	EL3C01	63	41
*25	EL3C02	63	41
32	EL3C03	72	45
40	EL3C04	80	50
50	EL3C05	110	60
63	EL3C06	112	61
75	EL3C07	120	60
90	EL3C08	127	55
110	EL3C09	153	84
125	EL3C10	172	85
160	EL3C12	200	102
180	EL3C13	245	126
200	EL3C14	248	117
225	EL3C15	243	111
250	EL3C16	250	95
315	EL3C18	329	120
355	EL3C19	325	118
400	EL3C20	376	120
450	EL3C21	380	120
500	EL3C22	390	120

● Producing up to size 315 mm with SDR 9 and SDR 7.4

* Future Products

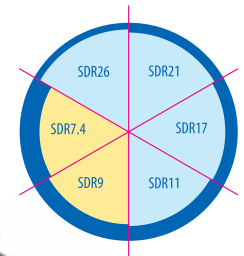
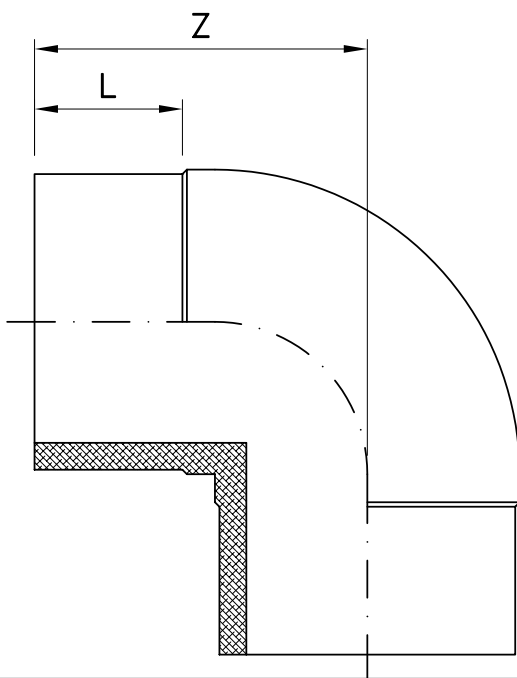

Nominal size (mm)	Code	Z (mm)	L (mm)
*25	EL1C02	63	41
*32	EL1C03	72	44
*40	EL1C04	80	49
50	EL1C05	92	58
63	EL1C06	94	58
75	EL1C07	105	60
90	EL1C08	120	79
110	EL1C09	121	85
125	EL1C10	130	88
160	EL1C12	148	85
180	EL1C13	166	106
200	EL1C14	180	117
225	EL1C15	184	111
250	EL1C16	210	128
315	EL1C18	206	102
*355	EL1C19	200	120
400	EL1C20	222	118

● Producing up to size 315 mm with SDR 9 and SDR 7.4

*Future Products

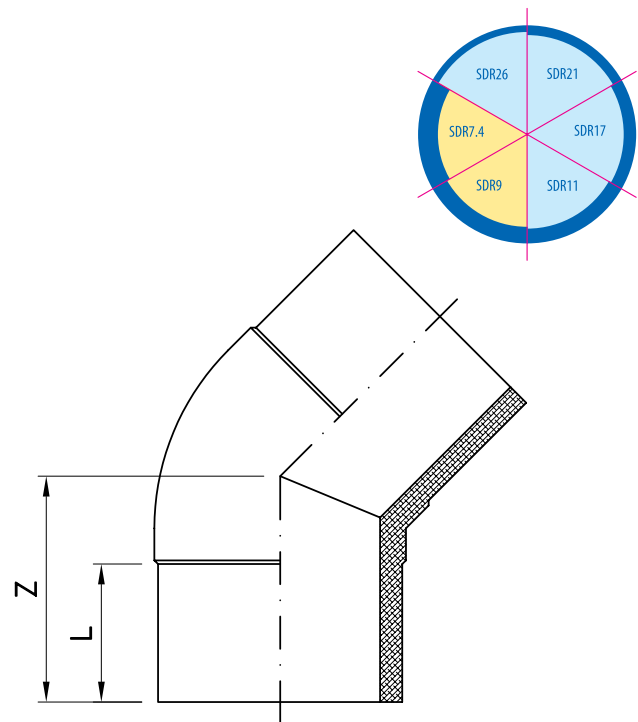

Nominal size (mm)	Code			Zmin (mm)	L (mm)
	11.25°	22.5°	30°		
50	EL8C05	EL9C05	EL10C05	90	58
63	EL8C06	EL9C06	EL10C06	90	58
75	EL8C07	EL9C07	EL10C07	95	60
90	EL8C08	EL9C08	EL10C08	110	79
110	EL8C09	EL9C09	EL10C09	95	85
125	EL8C10	EL9C10	EL10C10	130	88
160	EL8C12	EL9C12	EL10C12	140	85
180	EL8C13	EL9C13	EL10C13	160	106
200	EL8C14	EL9C14	EL10C14	170	117
225	EL8C15	EL9C15	EL10C15	185	111
250	EL8C16	EL9C16	EL10C16	200	128
315	EL8C18	EL9C18	EL10C18	230	102
355	EL8C19	EL9C19	EL10C19	210	120
400	EL8C20	EL9C20	EL10C20	210	118

Note: Welded design

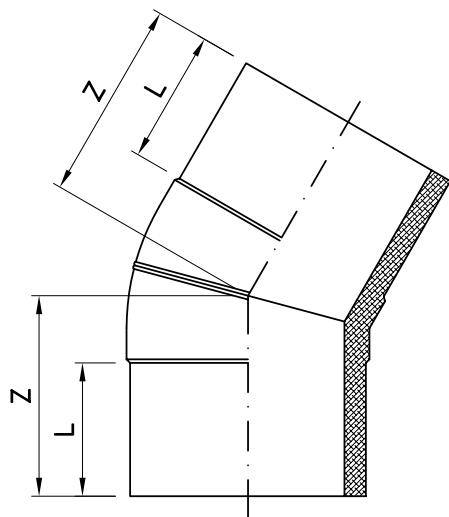
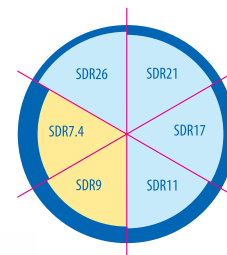

Concentric Reducer long spigot

HDPE 100 Литые Одноступенчатые Переходники

Nominal size (mm)	Code	L1 (mm)	L (mm)	Lt (mm)
*40×32	RE1C0403	45	50	125
50×25	RE1C0502	48	59	134
50×32	RE1C0503	33	56	122
50×40	RE1C0504	35	56	125
63×32	RE1C0603	39	59	131
63×40	RE1C0604	49	56	132
63×50	RE1C0605	59	51	127
75×50	RE1C0705	57	66	148
75×63	RE1C0706	62	68	144
90×63	RE1C0806	51	69	139
90×75	RE1C0807	66	69	152
110×20	RE1C0901	41	77	154
110×32	RE1C0903	41	77	154
110×63	RE1C0906	54	80	168
110×75	RE1C0907	54	77	167
110×90	RE1C0908	64	82	167
125×90	RE1C1008	73	91	210
125×110	RE1C1009	63	74	151
160×90	RE1C1208	87	76	212
160×110	RE1C1209	83	101	227
160×125	RE1C1210	70	94	215
200×110	RE1C1409	88	101	248
200×160	RE1C1412	86	132	283
250×110	RE1C1609	85	120	285
250×160	RE1C1612	96	121	294
250×200	RE1C1614	88	122	287
*315×250	RE1C1816	135	88	300
500×400	RE1C2220			
500×450	RE1C2221			
560×400	RE1C2320			
560×450	RE1C2321			
560×500	RE1C2322	100	100	380
630×400	RE1C2420			
630×450	RE1C2421			
630×500	RE1C2422			
630×560	RE1C2423			

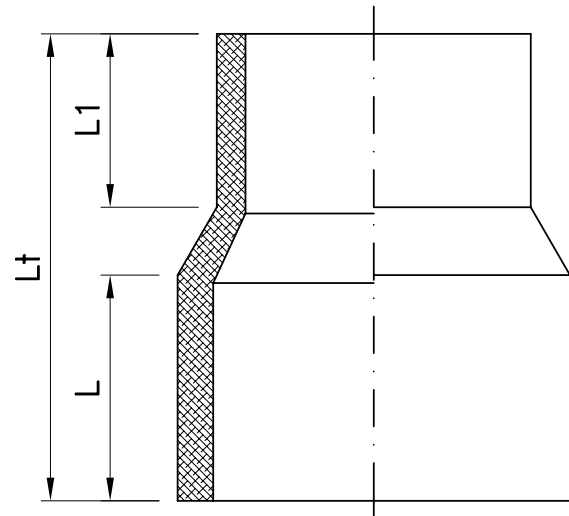
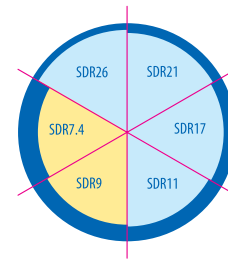

● Producing up to size 315 mm with SDR 9 and SDR 7.4

*Future Products

Nominal size (mm)	Sub Dimension (mm)	Code	L1 (mm)	L2 (mm)	Lt (mm)	L (mm)
140×75	90×75	RE2C0807	25	17	54	201
	110×90	RE2C0908	30	25	80	
	110×75	RE2C0907	30	17	116	
	125×75	RE2C1007	30	30	155	
	125×90	RE2C1008	30	25	135	
	125×110	RE2C1009	30	30	72	
	140×75	RE2C1107	31	17	201	
	140×90	RE2C1108	31	25	172	
	140×110	RE2C1109	31	30	120	
	140×125	RE2C1110	31	30	75	
200×110	125×110	RE2C1009	25	25	56	220
	160×110	RE2C1209	35	25	121	
	160×125	RE2C1210	35	25	70	
	180×110	RE2C1309	31	25	165	
	180×125	RE2C1310	31	25	100	
	180×160	RE2C1312	31	35	78	
	200×110	RE2C1409	36	25	220	
	200×125	RE2C1410	36	25	111	
	200×160	RE2C1412	36	35	145	
	200×180	RE2C1413	36	31	94	
315×160	200×160	RE2C1412	29	30	80	265
	225×160	RE2C1512	29	30	121	
	225×200	RE2C1514	28	29	70	
	250×160	RE2C1612	30	30	158	
	250×200	RE2C1614	30	29	108	
	250×225	RE2C1615	30	28	70	
	280×160	RE2C1712	28	30	201	
	280×200	RE2C1714	28	29	146	
	280×225	RE2C1715	28	28	109	
	280×250	RE2C1716	28	30	68	
	315×160	RE2C1812	47	30	265	
	315×200	RE2C1814	47	29	212	
	315×225	RE2C1815	47	28	172	
	315×250	RE2C1816	47	30	131	
	315×280	RE2C1817	47	28	91	

HDPE 100 Concentric Reducer short spigot Литые Одноступенчатые Переходник

Nominal size (mm)	Sub Dimension (mm)	Code	L1 (mm)	L2 (mm)	Lt (mm)	L (mm)
400x200	225x200	RE2C1514	41	31	64	395
	250x200	RE2C1614	40	31	148	
	250x225	RE2C1615	40	41	98	
	315x200	RE2C1814	39	31	240	
	315x225	RE2C1815	39	41	188	
	315x250	RE2C1816	39	40	129	
	355x200	RE2C1914	39	31	307	
	355x225	RE2C1915	39	41	257	
	355x250	RE2C1916	39	40	198	
	355x315	RE2C1918	39	39	109	
	400x200	RE2C2014	63	31	395	
	400x225	RE2C2015	63	41	350	
	400x250	RE2C2016	63	40	290	
	400x315	RE2C2018	63	39	200	
400x355	RE2C2019	63	39	132		

● Producing up to size 400 mm with SDR 9 and SDR 7.4

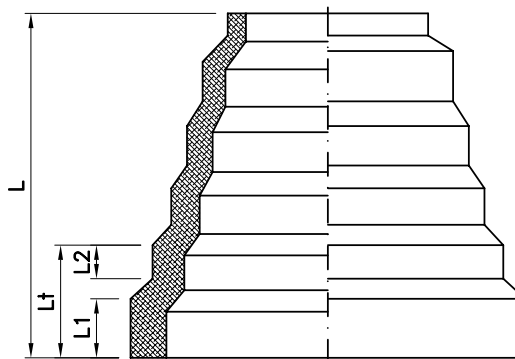
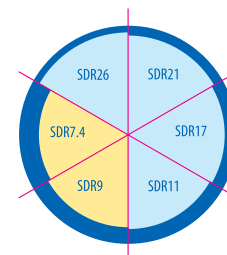

Nominal size (mm)	Code	Z (mm)	L (mm)
*25	CA1C02	50	40
*32	CA1C03	50	40
40	CA1C04	63	57
50	CA1C05	63	57
63	CA1C06	65	52
75	CA1C07	78	57
90	CA1C08	88	65
110	CA1C09	91	68
125	CA1C10	100	79
160	CA1C12	122	88
200	CA1C14	135	114
*250	CA1C16	205	120
*315	CA1C18	225	150

- Producing up to size 315 mm with SDR 9 and SDR 7.4
- * Future Products

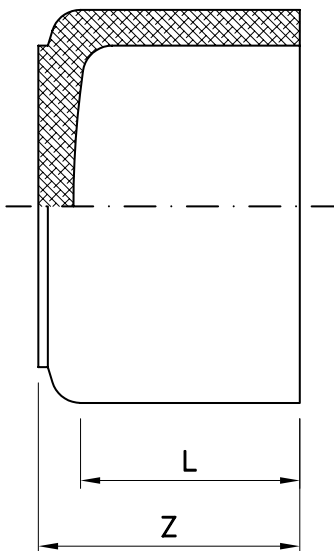
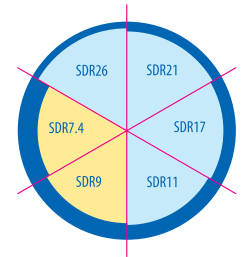

Nominal size (mm)	Code	Zk (mm)	Le (mm)
90	CR1C08	149	80
110	CR1C09	165	85
*125	CR1C10	175	85
160	CR1C12	206	100
200	CR1C14	245	118
250	CR1C16	303	144
*315	CR1C18	330	155

● Producing up to size 315 mm with SDR 9 and SDR 7.4
* Future Products

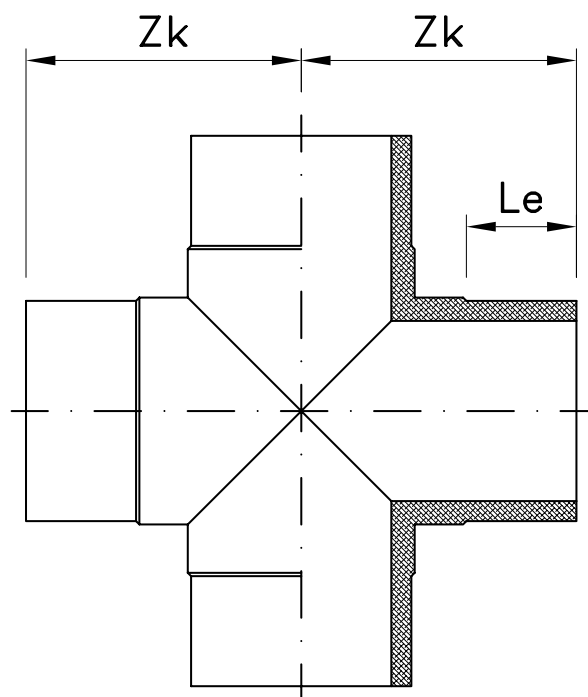
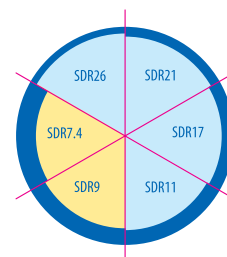

Nominal size (mm)	Code	D (mm)		P (mm)	Z (mm)	T (mm)	H (mm)		Bolt Number
		PN16	PN10				PN16	PN10	
63	FL5C06	165	165	125	82	18	18	18	4
75	FL5C07	185	185	145	100	18	18	18	8
90	FL5C08	200	200	160	106	20	18	18	8
110	FL5C09	220	220	180	112	20	18	18	8
125	FL5C10	220	220	180	124	22	18	18	8
160	FL5C12	285	285	240	132	25	22	22	8
200	FL5C14	340	340	295	140	25	22	22	12-8
250	FL5C16	405	395	350	160	30	26	22	12
315	FL5C18	460	445	400	180	35	26	22	12
*355	FL5C19	520	505	460	225	40	26	22	16
*400	FL5C20	580	565	515	240	40	30	26	16

- Could be weld with electrofusion coupler.
- Ring Steel : DIN2501
- *Future Products

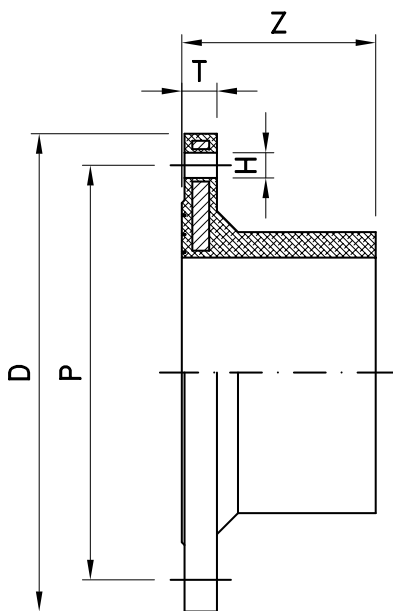
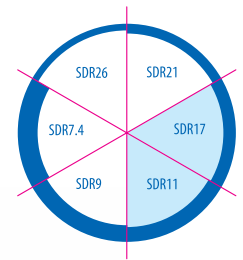

Nominal size (mm)	Code	D (mm)	P (mm)	Z1 (mm)	Z (mm)	T ±2 (mm)	Bolt Number
90	TE6C08	200	160	148	309	20	8
110	TE6C09	215	180	165	360	20	8
125	TE6C10	245	180	214	430	20	8
160	TE6C12	280	240	247	500	20	8
200	TE6C14	342	295	300	595	22	8
250	TE6C16	395	350	295	600	26	12
315	TE6C18	445	400	171	595	30	12

- PN4 bar and 6 bar : without backing ring
- PN10 bar : With backing ring
- PN16 & 10 bar : Using steel core hole flange

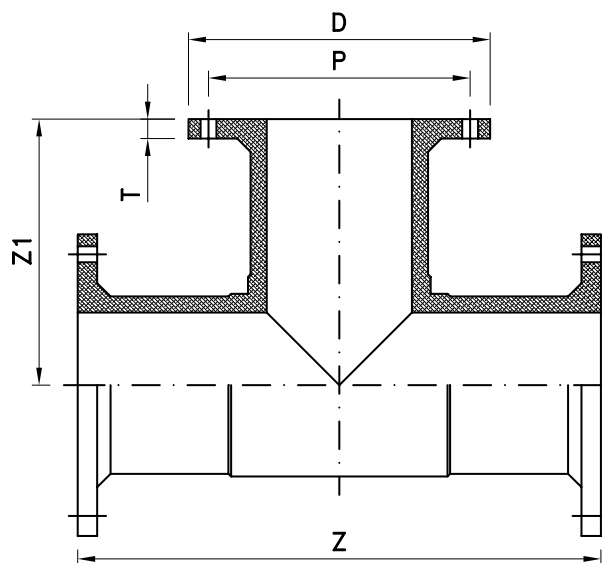
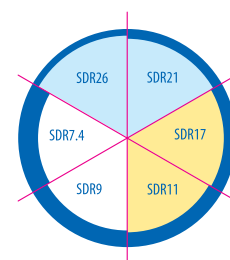

Nominal size (mm)	Code	D1 (mm)	D2 (mm)	P1 (mm)	P2 (mm)	Z1 (mm)	Z2 (mm)	T1 ±2 (mm)	T2 ±2 (mm)	Bolt Number
110×75	TE7C0907	217	183	180	145	360	174	20	18	8-4
110×90	TE7C0908	218	195	180	160	360	172	22	22	8-8
160×75	TE7C1207	278	183	240	145	495	248	22	18	8-4
160×90	TE7C1208	278	195	240	160	495	248	22	22	8-8
160×110	TE7C1209	278	218	240	180	495	248	22	20	8-8
200×90	TE7C1408	335	195	295	160	593	303	22	20	8-8
200×110	TE7C1409	340	219	295	180	590	301	22	20	8-8
200×160	TE7C1412	340	278	295	240	590	301	22	22	8-8
250×90	TE7C1608	395	200	350	160	600	300	26	20	12-8
250×110	TE7C1609	395	218	350	180	600	300	26	20	12-8
250×160	TE7C1612	395	282	350	240	585	295	28	22	12-8
315×90	TE7C1808	444	200	400	160	595	300	30	22	12-8
315×110	TE7C1809	444	218	400	180	595	300	30	22	12-8
315×160	TE7C1812	444	280	400	240	600	302	30	24	12-8
315×200	TE7C1814	444	338	400	295	595	300	30	26	12-8

- PN4 bar and 6 bar : without backing ring
- PN10 bar : With backing ring
- PN16 & 10 bar : Using steel core hole flange

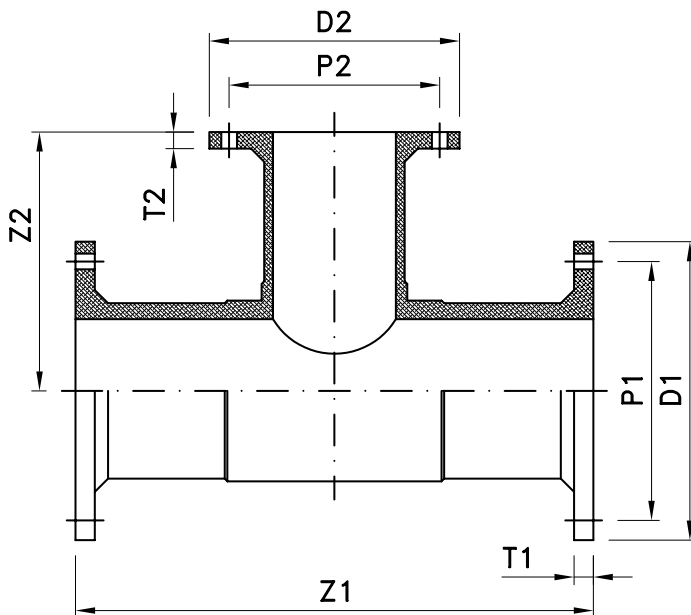
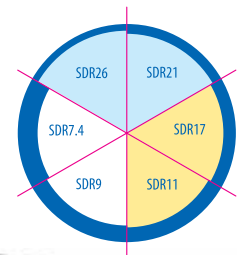

HDPE 100

Flat Face Flanged Elbow 90° Фланцевые Угольники 90°

Nominal size (mm)	Code	D (mm)	P (mm)	Z (mm)	T±2 (mm)	Bolt Number
90	EL6C08	200	160	152	18	8
110	EL6C09	215	180	183	20	8
125	EL6C10	243	180	218	20	8
160	EL6C12	280	240	300	22	8
200	EL6C14	340	295	280	22	8
250	EL6C16	395	350	300	24	12
315	EL6C18	445	400	300	28	12

- PN4 bar and 6 bar : without backing ring
- PN10 bar : With backing ring
- PN16 & 10 bar : Using steel core hole flange

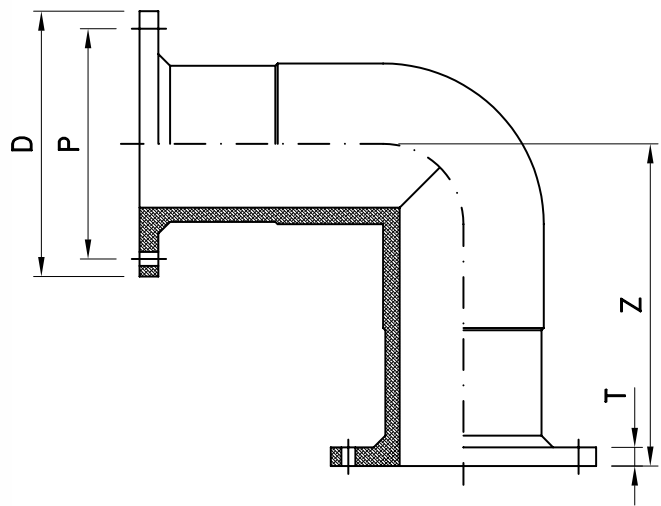
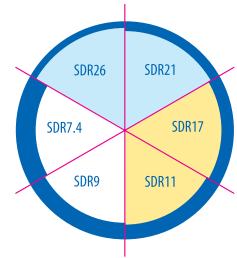

Nominal size (mm)	Code	D (mm)	P (mm)	H (mm)	T±2 (mm)	Bolt Number
63	CA2C06	164	125	96	18	4
75	CA2C07	185	145	110	18	4
90	CA2C08	195	160	120	18	8
110	CA2C09	219	180	141	27	8
125	CA2C10	248	180	138	25	8
160	CA2C12	282	240	155	22	8
200	CA2C14	340	295	165	22	8

- PN4 bar and 6 bar : without backing ring
- PN10 bar : With backing ring
- PN16 & 10 bar : Using steel core hole flange

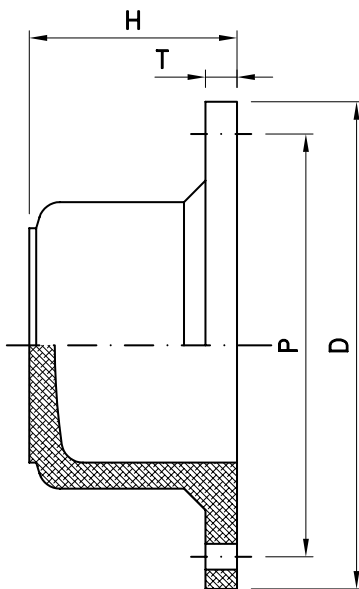
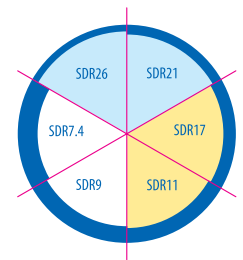

Nominal size (mm)	Code	Zmin (mm)	* r (mm)	Le (mm)
90	EL4C08	261	135	150
110	EL4C09	315	165	150
125	EL4C10	338	188	150
140	EL4C11	360	210	150
160	EL4C12	390	240	150
180	EL4C13	420	270	150
200	EL4C14	450	300	150
225	EL4C15	488	338	150
250	EL4C16	625	375	250
280	EL4C17	670	420	250
315	EL4C18	773	473	300
355	EL4C19	833	533	300
400	EL4C20	900	600	300
450	EL4C21	975	675	300
500	EL4C22	1100	750	350
560	EL4C23	1190	840	350
630	EL4C24	1295	945	350
710	EL4C25	1415	1065	350
800	EL4C26	1550	1200	350
900	EL4C27	1750	1350	400
1000	EL4C28	1900	1500	400

• Segment-welded fittings have a pressure reduction factor of 0.8

* $r = 1.5d$

$\alpha = \pm 2^\circ$

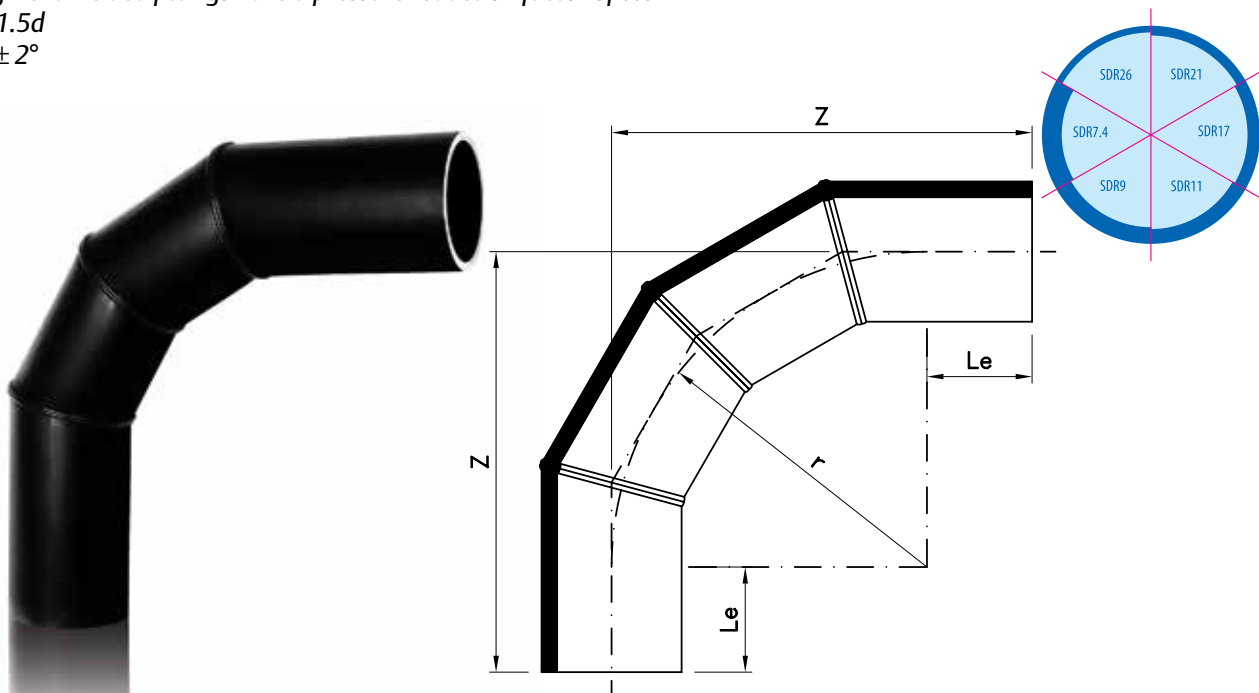

Nominal size (mm)	Code		Zmin (mm)		* r (mm)	Le (mm)
	45°	60°	45°	60°		
90	EL2C08	EL11C08	189	207	165	150
110	EL2C09	EL11C09	218	245	165	150
125	EL2C10	EL11C10	228	258	188	150
140	EL2C11	EL11C11	237	271	210	150
160	EL2C12	EL11C12	249	288	240	150
180	EL2C13	EL11C13	262	305	270	150
200	EL2C14	EL11C14	274	323	300	150
225	EL2C15	EL11C15	290	345	338	150
250	EL2C16	EL11C16	412	466	375	250
280	EL2C17	EL11C17	424	492	420	250
315	EL2C18	EL11C18	498	576	473	300
355	EL2C19	EL11C19	520	606	533	300
400	EL2C20	EL11C20	548	646	600	300
450	EL2C21	EL11C21	580	689	675	300
500	EL2C22	EL11C22	665	783	750	350
560	EL2C23	EL11C23	698	835	840	350
630	EL2C24	EL11C24	741	896	945	350
710	EL2C25	EL11C25	792	965	1065	350
800	EL2C26	EL11C26	847	1043	1200	350
900	EL2C27	EL11C27	960	1179	1350	400
1000	EL2C28	EL11C28	1022	1266	1500	400

• Segment-welded fittings have a pressure reduction factor of 0.8

* $r=1.5d$

$\alpha = \pm 2^\circ$

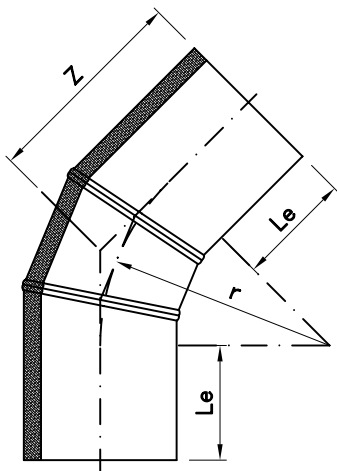
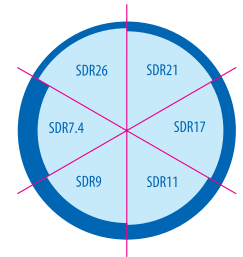

Nominal size (mm)	Code	Zk1 min (mm)	L1 (mm)	Le1 min (mm)
90	TE2C08	170	360	150
110	TE2C09	205	410	150
125	TE2C10	215	430	150
140	TE2C11	220	440	150
160	TE2C12	230	460	150
180	TE2C13	240	480	150
200	TE2C14	250	500	150
225	TE2C15	265	530	150
250	TE2C16	375	750	250
280	TE2C17	390	780	250
315	TE2C18	460	920	300
355	TE2C19	480	960	300
400	TE2C20	500	1000	300
450	TE2C21	525	1050	300
500	TE2C22	600	1200	350
560	TE2C23	630	1260	350
630	TE2C24	665	1330	350
710	TE2C25	705	1410	350
800	TE2C26	750	1500	350
900	TE2C27	850	1700	400
1000	TE2C28	900	1800	400

• Segment-welded fittings have a pressure reduction factor of 0.6

$\alpha = \pm 2^\circ$

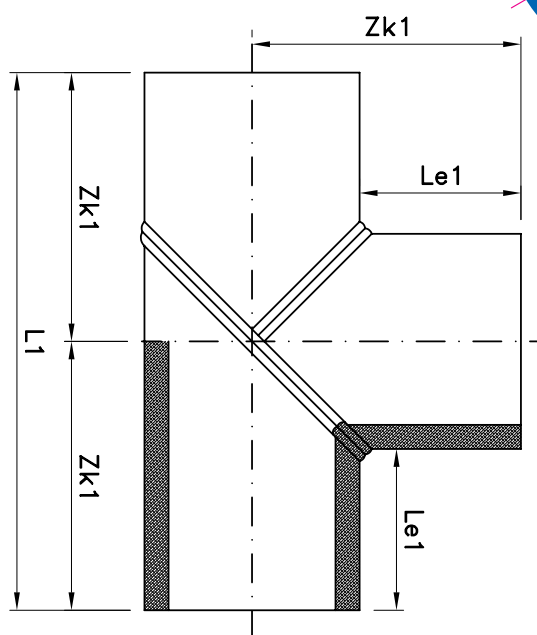
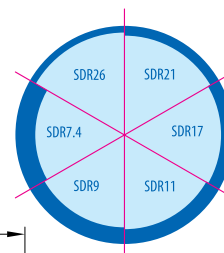

Nominal size (mm)	Code	Z ₁ (mm)	Z ₂ min (mm)
315 × 125	TE9C1810	1000	475
315 × 110	TE9C1809		
315 × 90	TE9C1808		
315 × 75	TE9C1807		
315 × 63	TE9C1806		
355 × 125	TE9C1910	1000	477
355 × 110	TE9C1909		
355 × 90	TE9C1908		
355 × 75	TE9C1907		
355 × 63	TE9C1906		
400 × 160	TE9C2012	1000	500
400 × 125	TE9C2010		
400 × 110	TE9C2009		
400 × 90	TE9C2008		
400 × 75	TE9C2007		
400 × 63	TE9C2006		
450 × 180	TE9C2113	1000	525
450 × 160	TE9C2112		
450 × 125	TE9C2110		
450 × 110	TE9C2109		
450 × 90	TE9C2108		
450 × 75	TE9C2107		
450 × 63	TE9C2106		
500 × 200	TE9C2214	1000	550
500 × 180	TE9C2213		
500 × 160	TE9C2212		
500 × 125	TE9C2210		
500 × 110	TE9C2209		
500 × 90	TE9C2208		
500 × 75	TE9C2207		
500 × 63	TE9C2206		
560 × 225	TE9C2315	1000	580
560 × 200	TE9C2314		
560 × 180	TE9C2313		
560 × 160	TE9C2312		
560 × 125	TE9C2310		
560 × 110	TE9C2309		
560 × 90	TE9C2308		

Nominal size (mm)	Code	Z ₁ (mm)	Z ₂ min (mm)
630 × 250	TE9C2416	1200	815
630 × 225	TE9C2415		
630 × 200	TE9C2414		
630 × 180	TE9C2413		
630 × 160	TE9C2412		
710 × 280	TE9C2517	1200	855
710 × 250	TE9C2516		
710 × 225	TE9C2515		
710 × 200	TE9C2514		
710 × 180	TE9C2513		
710 × 160	TE9C2512		
800 × 315	TE9C2618	1200	900
800 × 280	TE9C2617		
800 × 250	TE9C2616		
800 × 225	TE9C2615		
800 × 200	TE9C2614		
800 × 160	TE9C2612		
900 × 355	TE9C2719	1200	950
900 × 315	TE9C2718		
900 × 280	TE9C2717		
900 × 250	TE9C2716		
900 × 225	TE9C2715		
900 × 200	TE9C2714		
900 × 160	TE9C2712		
900 × 160	TE9C2712		

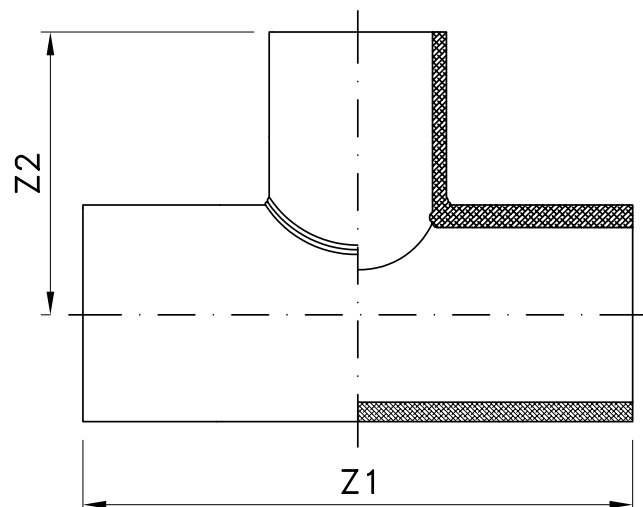
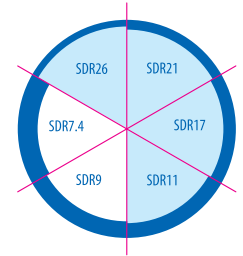

Nominal size (mm)	Code	Z (mm)	L (mm)	Z1 min (mm)	
90	TE3C08	295	445	150	
110	TE3C09	325	500		
125	TE3C10	355	545		
140	TE3C11	375	581		
160	TE3C12	412	642		
180	TE3C13	450	700		
200	TE3C14	487	759		
225	TE3C15	530	830		
250	TE3C16	580	905		250
280	TE3C17	630	995		300
315	TE3C18	690	1090		
355	TE3C19	730	1155		
400	TE3C20	800	1250		
450	TE3C21	850	1325		
500	TE3C22	900	1400		
560	TE3C23	950	1480	350	
630	TE3C24	1000	1545	350	
710	TE3C25	1090	1670		
800	TE3C26	1180	1810		
900	TE3C27	1320	1990		400
1000	TE3C28	1360	2070	400	

• Segment-welded fittings have a pressure reduction factor of 0.6
 $\alpha = \pm 2^\circ$

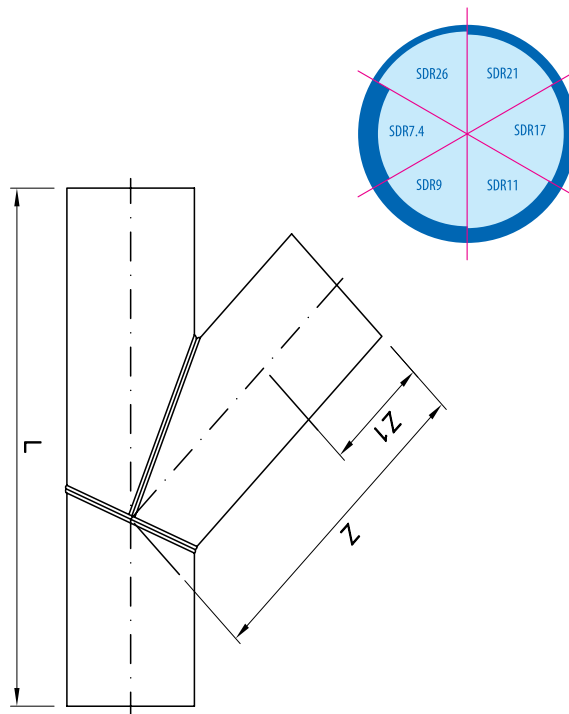

Fabricated Cross 90° Изготовленный крест 90°

Nominal size (mm)	Code	Zk1 min (mm)	L1 (mm)	Le1 min (mm)
90	CR2C08	170	360	150
110	CR2C09	205	410	150
125	CR2C10	215	430	150
140	CR2C11	220	440	150
160	CR2C12	230	460	150
180	CR2C13	240	480	150
200	CR2C14	250	500	150
225	CR2C15	265	530	150
250	CR2C16	375	750	250
280	CR2C17	390	780	250
315	CR2C18	460	920	300
355	CR2C19	480	960	300
400	CR2C20	500	1000	300
450	CR2C21	525	1050	300
500	CR2C22	600	1200	350
560	CR2C23	630	1260	350
630	CR2C24	665	1330	350
710	CR2C25	705	1410	350
800	CR2C26	750	1500	350
900	CR2C27	850	1700	400
1000	CR2C28	900	1800	400

• Segment-welded fittings have a pressure reduction factor of 0.6
 $\alpha = \pm 2^\circ$

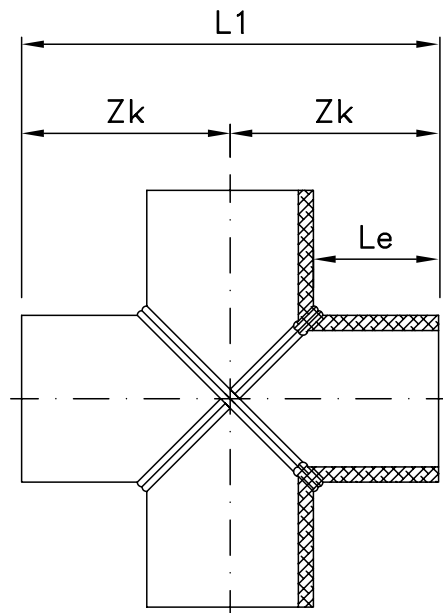
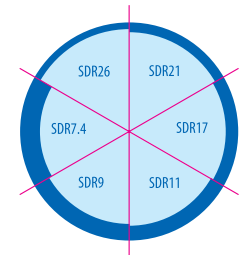

Flange Size (mm)	Code	D (mm)	d3 (mm)	K (mm)	d2 (mm)	Bolt Number	Bolt Size	T±1.5 (mm)
63	RI1C06	165	78	125	18	4	M 16	18
75	RI1C07	185	92	145	18	4	M 16	18
90	RI1C08	201	108	160	18	8	M 16	20
110	RI1C09	221	130	180	18	8	M 16	20
125	RI1C10	251	135	180	18	8	M 16	20
160	RI1C12	286	177	240	22	8	M 20	24
200	RI1C14	340	235	295	22	8	M 20	24
225	RI1C15	340	238	295	22	8	M 20	24
250	RI1C16	409	288	350	22	12	M 20	30
315	RI1C18	463	338	400	22	12	M 20	34
*355	RI1C19	520	376	470	26	16	M20	40
*400	RI1C20	580	430	525	30	16	M24	40

● Possible To use For PN6 & PN10 .

• Ring Steel : DIN2501

* Future Products

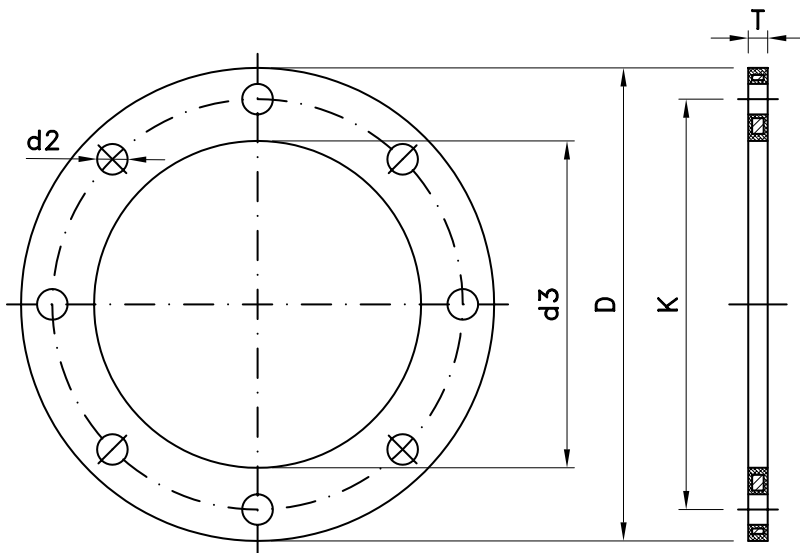
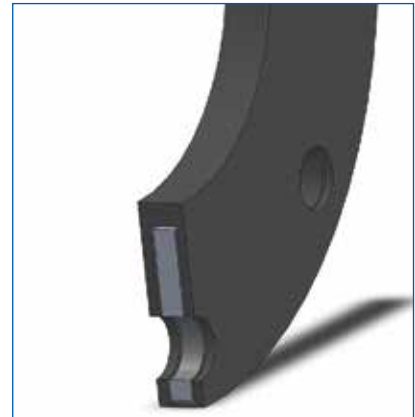
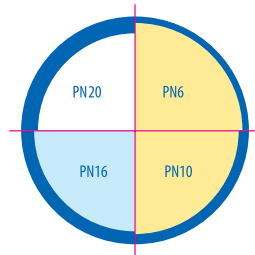

Backing Ring (EN 1092 - 2013) - PN10 Металлические Кольца

DN	Pipe Outside (mm)	Code	D (mm)	K (mm)	d2 (mm)	Bolting	
						Number	Size
20	25	RI4S02	105	75	14	4	M12
25	32	RI4S03	115	85	14	4	M12
32	40	RI4S04	140	100	18	4	M16
40	50	RI4S05	150	110	18	4	M16
50	63	RI4S06	165	125	18	4	M16
65	75	RI4S07	185	145	18	8	M16
80	90	RI4S08	200	160	18	8	M16
100	110	RI4S09	220	180	18	8	M16
100	125	RI4S10	220	180	18	8	M16
125	140	RI4S11	250	210	18	8	M16
150	160	RI4S12	285	240	22	8	M20
150	180	RI4S13	285	240	22	8	M20
200	200	RI4S14	340	295	22	8	M20
200	225	RI4S15	340	295	22	8	M20
250	250	RI4S16	395	350	22	12	M20
250	280	RI4S17	395	350	22	12	M20
300	315	RI4S18	445	400	22	12	M20
350	355	RI4S19	505	460	22	16	M20
400	400	RI4S20	565	515	26	16	M24
450	450	RI4S21	615	565	26	20	M24
500	500	RI4S22	670	620	26	20	M24
600	630	RI4S24	780	725	30	20	M27

Note: Thickness According to Customer Order

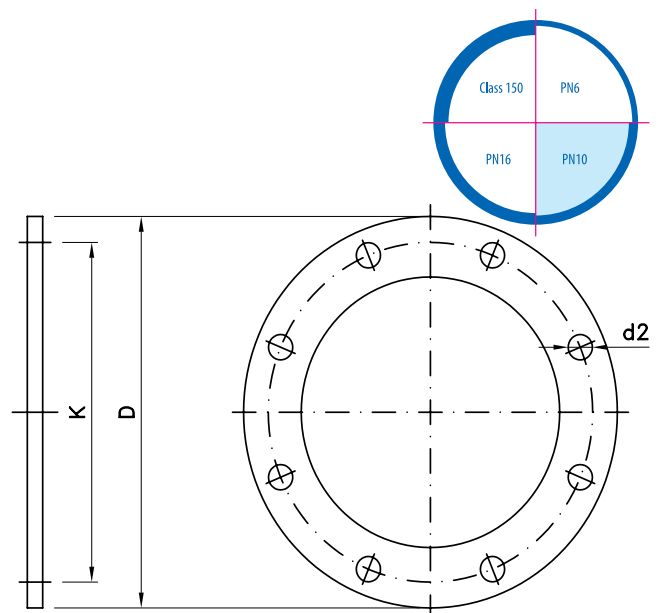

Backing Ring (EN 1092 - 2013) - PN16

Металлические Кольца

DN	Pipe Outside (mm)	Code	D (mm)	K (mm)	d2 (mm)	Bolting	
						Number	Size
20	25	RI5S02	105	75	14	4	M12
25	32	RI5S03	115	85	14	4	M12
32	40	RI5S04	140	100	18	4	M16
40	50	RI5S05	150	110	18	4	M16
50	63	RI5S06	165	125	18	4	M16
65	75	RI5S07	185	145	18	8	M16
80	90	RI5S08	200	160	18	8	M16
100	110	RI5S09	220	180	18	8	M16
100	125	RI5S10	220	180	18	8	M16
125	140	RI5S11	250	210	18	8	M16
150	160	RI5S12	285	240	22	8	M20
150	180	RI5S13	285	240	22	8	M20
200	200	RI5S14	340	295	22	12	M20
200	225	RI5S15	340	295	22	12	M20
250	250	RI5S16	405	355	26	12	M24
250	280	RI5S17	405	355	26	12	M24
300	315	RI5S18	460	410	26	12	M24
350	355	RI5S19	520	470	26	16	M24
400	400	RI5S20	580	525	30	16	M27
450	450	RI5S21	640	585	30	20	M27
500	500	RI5S22	715	650	33	20	M30
600	630	RI5S24	840	770	36	20	M33

Note :Thickness According to Customer Order

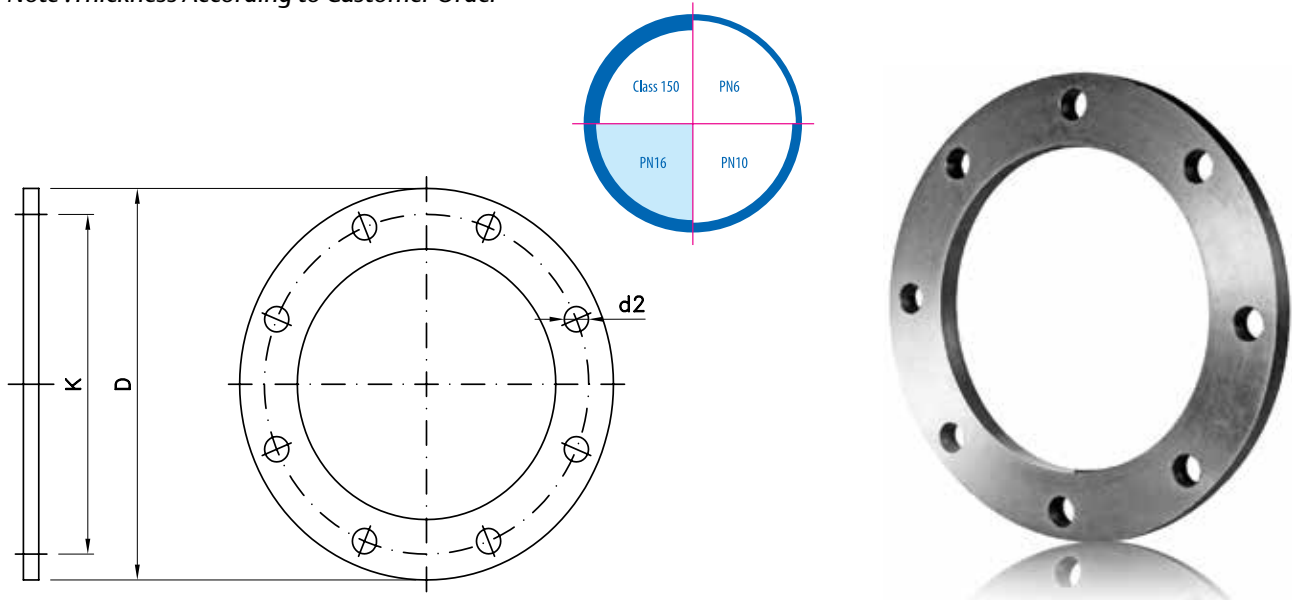

Gasket прокладка

Pipe Outside Diameter (mm)	Code	d10 Outside of Gasket (mm)	Pipe Series (Inside Of Gasket) d9 (mm)				b (mm)
			2	3	4	5	
20	GS1E01	45	-	-	-	16	2
25	GS1E02	58	-	-	21	20	2
32	GS1E03	68	-	-	28	26	2
40	GS1E04	78	-	36	35	33	2
50	GS1E05	88	-	46	44	41	2
63	GS1E06	102	59	58	56	51	2
75	GS1E07	122	70	69	66	61	2
90	GS1E08	138	84	83	80	74	2
110	GS1E09	158	103	101	97	90	3
125	GS1E10	158	117	115	111	102	3
140	GS1E11	188	131	129	124	114	3
160	GS1E12	212	150	148	142	131	3
180	GS1E13	212	169	166	160	147	3
200	GS1E14	268	188	185	177	164	3
225	GS1E15	268	211	208	199	184	3
250	GS1E16	320	234	231	222	204	3
280	GS1E17	320	263	258	248	229	3
315	GS1E18	370	295	291	279	258	3
355	GS1E19	430	333	328	315	290	3
400	GS1E20	482	375	369	355	327	3
450	GS1E21	585	422	415	399	368	3
500	GS1E22	585	469	461	443	409	3
560	GS1E23	685	525	517	497	456	3
630	GS1E24	685	590	581	559	513	3
710	GS1E25	800	666	655	630	-	3
800	GS1E26	905	750	738	709	-	3
900	GS1E27	1005	844	831	798	-	3
1000	GS1E28	1110	938	923	885	-	3
1200	GS1E29	1330	1126	1108	-	-	3

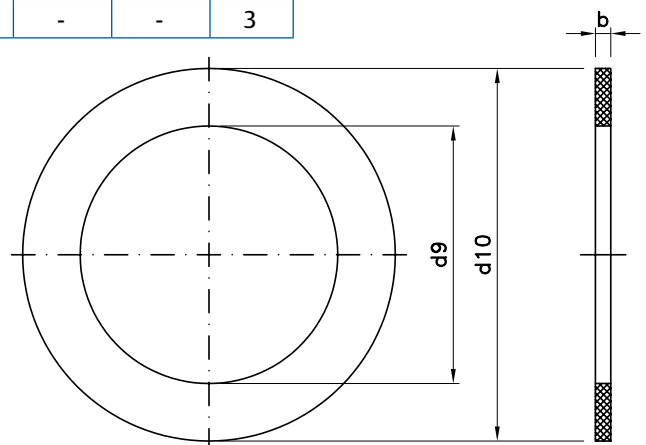
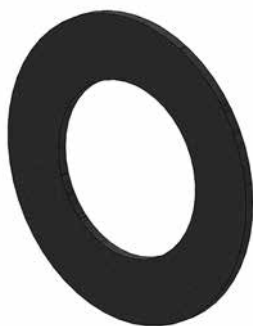
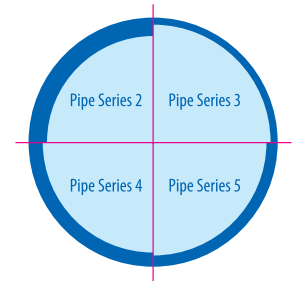

Nominal size (mm)	Code	R (in)	le (mm)	Zmin (mm)
20	TF1C01	1/2	40	85
25	TF1C02	3/4	50	106
32	TF1C03	1	50	115
40	TF1C04	1 1/4	50	125
50	TF1C05	1 1/2	55	130
63	TF1C06	2	55	129

• Could be weld with electrofusion coupler

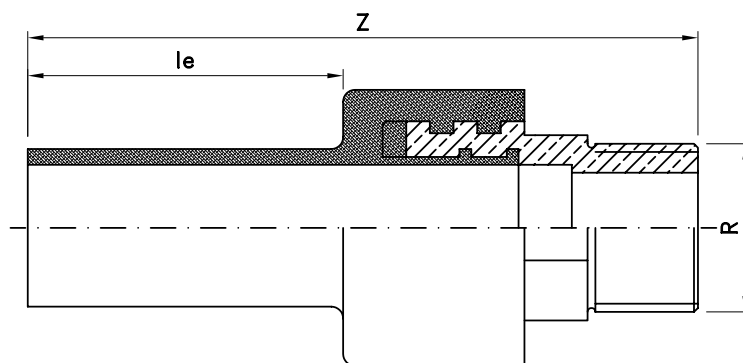
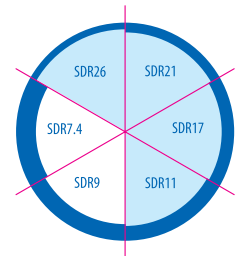



We are able to produce special fittings like collectors, concentric Reducer etc; according to customer order, technical and schematics.

Electrofusion Welding Machine Specification

Technical Data of electrofusion welding machine
HST300 Print+2.0



- Welding PE, PP pipe and fittings
- size: 20mm – 1200 mm

Automatic data logging	10,000 reports
Welding range	Up to pipe & fittings size 1200mm
Data input	Bar code scanner, optionally scanning pen; manual input of fitting code sequence or welding voltage and time; optionally Fusamatic welding; all inputs also possible with novel GT keyboard
Welding monitoring system	Welding voltage, resistance, welding current, established contact, short-circuit, ambient temperature, input frequency, input voltage, memory control, welding unit temperature, maintenance interval
System self-monitoring	System check, computerized maintenance management, incl. recording
Traceability pursuant to ISO 12176-2/4	Commission number 32 alphanumeric characters, ISO compliant welder ID code, additional data 20 and 15 alphanumeric characters, ISO-compliant pipe data, fitting data, pipe length, weather conditions, installing company, joint number, inventory number, info on servicing company
Data output with menu	USB interface (USB A) for data download as an abstract or extended report in the PDF format to a USB stick or a label tag printer, with tag print menu;
Display screen	Robust, hi-res temperature range-extended screen, character size 8 mm
Weight	16 kg
Dimensions	W 236 x H 295 x D 330 mm
Adaptor	4.0 mm in adapter bag
Ingress protection	IP54

Automatic temperature compensation	Yes
warranty	12 months
Miscellaneous	intuitive report review menu incl. search, View Weld feature, memory backup, Auto Weld feature, buzzer volume set point, measurement unit selection (inches/mm, °F/°C)
Languages	EN, DE, FR, BG, CS, ZH, NL, FI, GR, IT, NO, RO, SK, TR, RU,...
Production Standards and Approvals	CE, DVS, WEEE Reg. No. DE74849106, ISO 9001:2008, Ro HS compliance
Operation standards	EN1555, EN12201, ISO4427, INSO14427, IGS-M-PL-016(2), ISIRI11233
Output voltage	8 V - 48 V
Output current	Max. 110 A
Input voltage	180 V - 280 V
Input frequency	40 Hz - 70 Hz
Current consumption	AC 16 A
Power rating	3500 W
Recommended generator power	3.5 kVA
Temperature range	-20°C through +60°C
Power cord	5 m
Welding cable	4 m with 4.7 mm connection terminal

Butt Welding Machine Specification



Manual Hydraulic Unit

WeldControl 2.0 Unit

CNC ECO 2.0 Unit

Welding range O.D. (mm)	40 160	63 200	(63) 75 250	90 315	90 355	200 500	315 630	500 800	630 1000	630 1200	800 1400	800 1600
Reducer inserts												
40	✓											
50	✓											
63	✓	✓	✓									
75	✓	✓	✓									
90	✓	✓	✓	✓	✓							
110	✓	✓	✓	✓	✓							
125	✓	✓	✓	✓	✓							
140	✓	✓	✓	✓	✓							
160		✓	✓	✓	✓							
180		✓	✓	✓	✓							
200			✓	✓	✓	✓						
225			✓	✓	✓	✓						
250				✓	✓	✓						
280				✓	✓	✓						
315					✓	✓	✓					
355						✓	✓					
400						✓	✓					
450						✓	✓					
500							✓	✓				
560							✓	✓				
630							✓	✓	✓	✓		
710								✓	✓	✓		
800									✓	✓	✓	
900									✓	✓	✓	✓
1000										✓	✓	✓
1200											✓	✓
1400												✓

Introduction to plastics

History

As early as 1838 Viktor Regnault succeeded in producing polyvinylchloride in a laboratory by exposing vinyl chloride to the sun.

In 1912 Fritz Klatte discovered the fundamentals for the practical production of PVC.

During the World War I, plastics, which were still new, had to replace other materials falling into short supply.

They were then sometimes over specified with respect to their application. Therefore, plastics needed to be improved.

It was necessary to scrutinize the internal structure of these new materials closely. Only in 1938 did the production of plastics in any, significant volume begin, when the numerous application possibilities had been recognized.

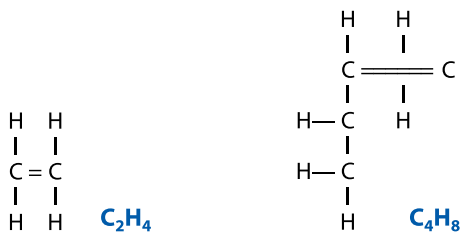

1- Ethylene-Monomer

2- Butylene-Monomer

Structure of plastics

Plastics are materials which are created by chemical conversion of natural products or in a synthetic, manner from organic, compounds. The main components are the elements **carbon (C)** and **hydrogen (H)**. The basis of most plastics are carbon-hydrogen compounds, from which the single components of plastics, the so-called monomers³⁾, are produced.

1- *Synthesis: production of a chemical compound from different elements or simple molecules. Synthesis is the opposite of analysis.*

2- *Organic media are pure non-metals of natural occurrence, e. g. petroleum, coal, wood, natural gas. Inorganic media are compounds of metal and non-metals, e. g. minerals, ores etc.*

3- *Monomers are the basic molecules, i. e. the smallest components of which plastics are built.*

The raw material

Raw materials for the manufacture of plastics are natural compounds, such as cellulose, coal, petroleum and natural gas. In a refinery, petroleum is separated into several components by means of distillation. Grouped into evaporation ranges, gas, benzene, petroleum, gaseous oil, and as a residue bitumen are obtained during distillation. All components consist of hydrocarbons which only differ in size and form of the molecules. The most important component for plastics production is crude benzene.

In a heat cracking process this crude benzene is broken down into ethylene, propylene, butylene and other hydrocarbons and is then modified.

The raw material

Raw materials for the manufacture of plastics are natural compounds, such as cellulose, coal, petroleum and natural gas. In a refinery, petroleum is separated into several components by means of distillation. Grouped into evaporation ranges, gas, benzene, petroleum, gaseous oil, and as a residue bitumen are obtained during distillation. All components consist of hydrocarbons which only differ in size and form of the molecules. The most important component for plastics production is crude benzene.

In a heat cracking process this crude benzene is broken down into ethylene, propylene, butylene and other hydrocarbons and is then modified.

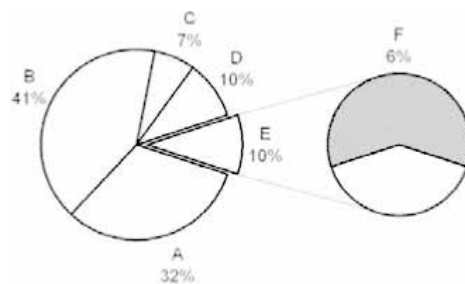

The production of plastics

A Heating 32 %

C Other 7 %

E Chemicals 10 %

B Traffic 41 %

D Industry 10 %

F incl. 6 % Plastics

Plastics are manufactured by compounding together large number of similar basic components (monomers) through chemical bonding.

Introduction to plastics

The plastic industry only consumes approximately 6% of the petroleum products originating from refineries.

In Germany the chemical industry uses approximately 10% of the entire crude oil consumption and this includes 6% for plastics.

To produce plastics three different processes are used:

- Polymerisation
- Polycondensation
- Polyaddition

Polymerisation

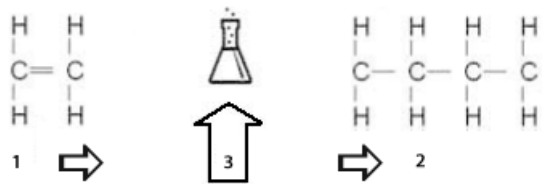

1-Monomer: Ethylene

2- Macromolecule chain: Polyethylene

3- Polymerisation process -->Energy, Catalyst, Additives

Polymerisation is the most frequently used procedure for the synthesis of plastics. Polymerisation means the lining up of macromolecule chains without separation of foreign matter.

For example polyethylene, polybutene, polypropylene, polyvinylchloride and other plastics are all reduced by means of polymerization.

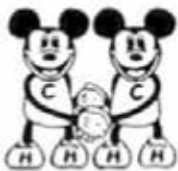

Examples:

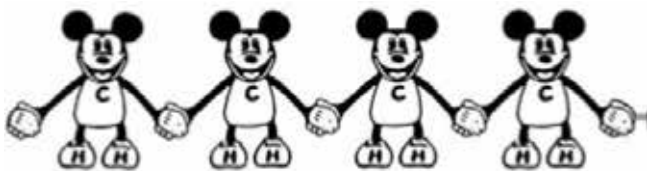

Ethylene C_2H_4

Polyethylene

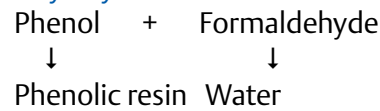

Polycondensation

During polycondensation similar and dissimilar monomers are lined up to become macromolecule chains, at the same time separating a byproduct, e. g. water, hydrochloric acid, etc.

Polycondensation is applied, for example, to produce phenolic resins and polyamids.

Polyaddition

During polyaddition macromolecules are created from chemically different molecules, however without separating a by-product.

The procedure is used for the production of polyurethanes and exposed resins (e. g. Araldit).

Classification of plastics

Plastics are subdivided into three main groups:

- Thermoplastics
- Thermosets
- Elastomers

Thermoplastics are again divided into:

- amorphous
- semi-crystalline

Thermosets are divided into:

- Resins
- Thermoelastics

Elastomers are divided into:

- Synthetic caoutchouc (rubber)

Distinction of plastics

In the production process, the procedure and the addition of additives (stabilisers, catalysts, fibres, slip additives, etc.) create macromolecules with different basic structures.

Thermoplastics

Thermoplastics consist of long filamentary molecules

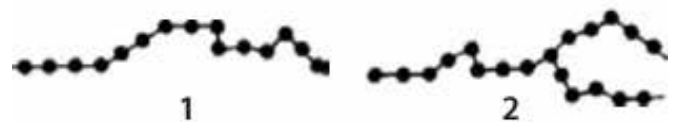

with or without branches.

Introduction to plastics

1- Filamentary molecule without branches

2- Filamentary molecules with branches

These filamentary molecules can be arranged as follows:

amorphous, i. e. in an inordinate structure or **semi-**

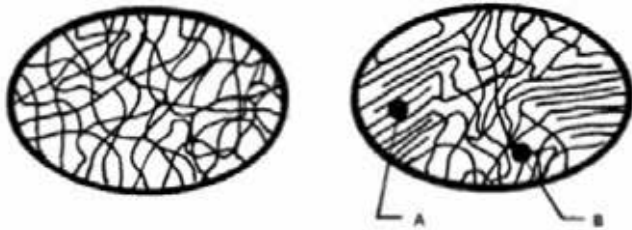

crystalline, i. e. in a partially ordinate structure
Crystallisation is increased by slow cooling.

A crystalline B amorphous

Semi-crystalline thermoplastics are polyolefines, for example:

Amorphous thermoplastics are styrenes and vinyl chlorides, for example:

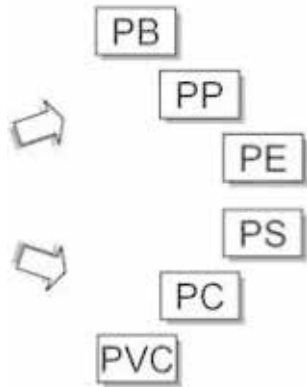

PE Polyethylene

PB Polybutene

PP Polypropylene

PVC Polyvinylchloride

PS Polystyrene

PC Polycarbonate

Thermoplastics are plastics with simple or branched filamentary molecules (macromolecules) which have an inordinate or partially ordinate structure. They distort during heating, melt and solidify again on cooling. This process can be repeated at all times. They can be plastically deformed, distended and recovered. Due to these properties, thermoplastics are suited for injection-moulding, extrusion and fusion. "Plastic deformation" is the processing of a material by means of e. g. injection moulding, extrusion etc. "Distension" is the longitudinal or longitudinal and transversal stretching of amorphous molecule chains to improve the material properties.

The "recovery ability" is the memory behavior of a

material where the materials is melted by heating and recover again in the original order during the cooling phrase.

Polyolefin belong to the semi-crystalline thermoplastics group. Compared with amorphous thermoplastics

(e. g. PVC-U, PVC-C) they show less tensile strength, hardness, melting temperature and a lower E modulus. However they exhibit higher impact resistance, elongation at rupture and thermal expansion.

Semi-crystalline thermoplastics are more suited for fusion jointing than amorphous thermoplastics which are ideal for solvent cement jointing.

----- amorphous ----- semi-crystalline

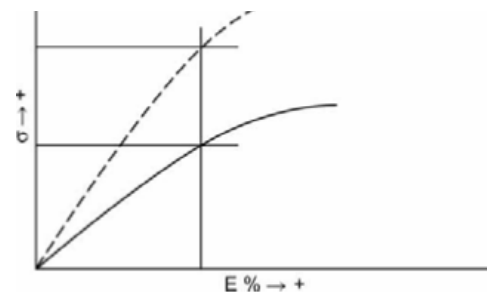

σ Tensile strength E Strain %

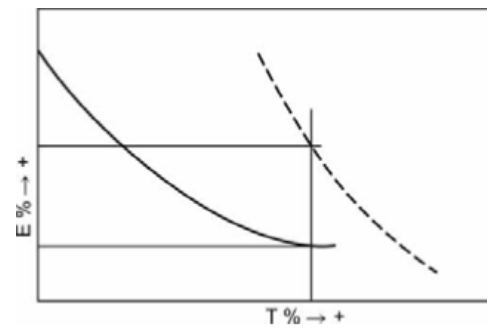

ϵ Strain T Temperature

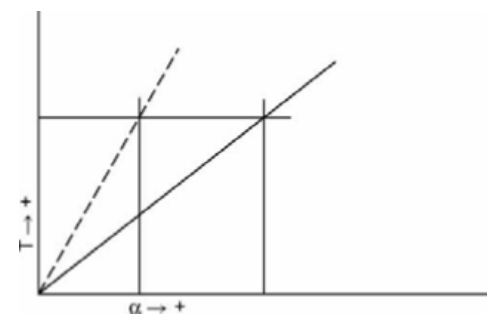

α Thermal expansion T Temperature

Introduction to plastics

Thermosets

By means of a hardener the polymer chains of the fluid and solid thermoset resins are cross-linked. Thermosets which have been hardened in this way cannot be melted, fused or deformed.

Thermosets are normally reinforced with glass, textile or carbon fibres and other filling materials.

PF Phenolic resin

EP Epoxy resin

UP Polyester resin

GFK Glass fibre plastic

CFK Carbon-fibre plastic

GF-EP Glass-fibre epoxy resin

CF-PF Carbon-fibre phenolic resin

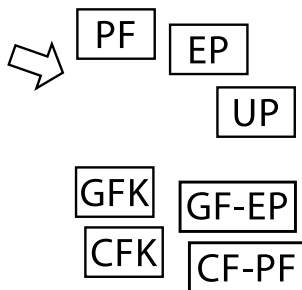
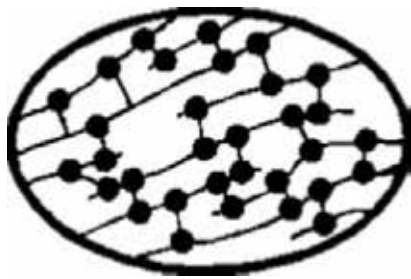

Elastomers

Elastomers are rubber-elastic plastics, also called “synthetic caoutchouc”. In contrast to thermosets, the network has a large mesh width. By means of vulcanization aids the polymer chains are cross-linked. The amount of the cross-links, determines the hardness (the hardness is indicated in Shore degrees of hardness) of the rubber. The elastomer is very elastic, cannot be melted, is not fusible, can be deformed, but not reshaped. Elastomers are for example:

NR Natural rubber

EPDM Ethylene propylene rubber

CR Chloroprene rubber

SI Silicone rubber

FPM Fluorocarbon rubber

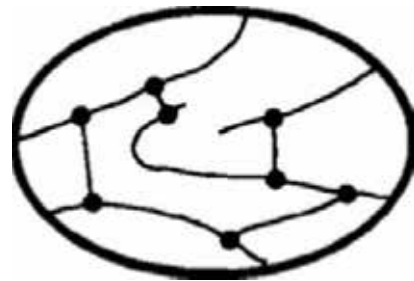

Wide meshed, low cross-linked elastomer net

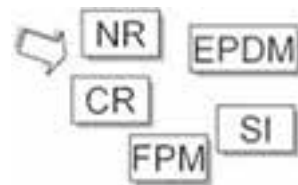

Introduction to plastics

Comparison of thermoplastics, thermosets and elastomers

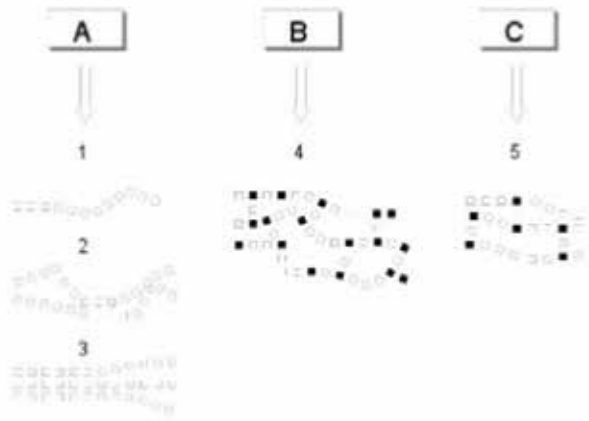

1 Filamentary molecules

2 Amorphous

3 Semi-crystalline

4 Space-net molecules, close-meshed

5 Space-net molecules, wide-meshed

A Thermoplastic

B Thermoset

C Elastomer

Thermoplastics

- repeated melting
- Fusible
- the amount of crystallites determines the density and mechanical properties
- Under strong mechanical stress they tend to creep and show lasting deformation
- The strength value decreases with increased heating
- can be transformed and deformed several times

Thermosets

- do not melt
- cannot be fused
- Number of links is decisive for mechanical properties can be deformed under mechanical load, but regain their original form after load is removed
- Only behave elastically in a relatively narrow upper

temperature range, therefore more heat stable

- can only be deformed once

Elastomers

- do not melt
- cannot be fused
- Number of links is decisive for the rubber hardness
- can be strongly deformed under mechanical stress
- remain elastic down to low temperatures

Relevant properties of thermoplastics

Compared to conventional materials, plastics offer the following general advantages:

- Low weight
- high elasticity
- chemical resistance
- low heat conduction
- smooth surfaces

The material polyethylene (PE)

PE properties (reference values)

Property		Value	Unit	Test Method	Test Specimen
Density at 23°C		0.958	g/cm ³	ISO 1183	10mm x 10mm x 4mm
Viscosity Number		380	ml/g	ISO 1628-3	0.1% solution of granules in decahydronaphthalene decahydronaphthalene
Melt Flow Rate	MFR 190/5	0.23	g/10min	ISO 1133	granules sample weight 3g to 6g
	MFR 190/21.6	6.5	g/10min		
Tensile Properties	Yield Stress	26	N/mm ²	ISO 527, Test Rate 50mm/min	ISO 3167, 4mm thick (test specimen no. 3, 4mm thick according to DIN 53 455)
	Elongation at Yield Stress	10	%	ISO 527, Test Rate 50mm/min	
	Tensile modulus of Elasticity (secant between 0.05 & 0.25% strain)	900	N/mm ²	ISO 527	
	Tensile Creep Modulus (1 hour value)	650	N/mm ²	ISO 899, Test Load 2M/mm ²	
	Tensile Creep Modulus (1000 hour Load 2M/mm ² value)	350	N/mm ²		
Flexural Properties	Flexural Creep Modulus (1 min value)	1100	N/mm ²	DIN 54852-Z4 $\sigma_b=2N/mm^2$	110mm x 10mm x 4mm loaded flat
	Flexural Stress (3.5%deflection)	20	N/mm ²	ISO 178, Test Rate 2mm/min	80mm x 10mm x 4mm
Stiffness in Torsion		180	N/mm ²	DIN 53447	60mm x 6.35mm x 3mm
Hardness	Ball Indentation Hardness	41	N/mm ²	ISO 2039 part 1 Test Load 132N	4mm sheet
	Shore Hardness D (3sec value)	61	~	ISO 868	6mm sheet
	Shore Hardness D (15sec value)	59	~		
Nothed Impact Strength acN (test specimen from compression moulded sheet)	at 23°C	20	kJ/m ²	ISO 179/1eA	80mm x 10mm x4mm
	at -30°C	10	kJ/m ²		
Vicat softening Point VST/B/50		67	°C	ISO 306	4mm sheet
Oxidation Induction Time	200°C in O ²	>=60	min	ISO TR 10837	granules

Introduction to plastics

General

Polymers which consist only of carbon and hydrogen (hydrocarbons) are called polyolefin. Polyethylene (PE) belongs to this group. It is a semi crystalline thermoplastic. Polyethylene is the best known standard polymer.

The chemical formula is: $(\text{CH}_2-\text{CH}_2)_n$. It is an environmentally friendly hydrocarbon product.

PE and PP belong to the non-polar materials. Because of this, the material does not dissolve in common solvents and, in addition, hardly swells. As a result, PE pipes cannot be solvent cemented. The appropriate jointing method for this material is welding. For piping installations we offer two welding techniques in our product range: butt fusion and electrofusion.

The latter jointing technique is preferred for piping systems transporting gas, water, compressed air or other less aggressive media. Butt welding are preferably used on a diameter-specific basis. High molecular PE grades of medium to high density have become state of the art for industrial piping installations.

The Stress Regression Line

Numerous actual test results, measured at 20°C and 60°C, over a range of times up to 10,000 hours, are plotted on a log scale and a regression line is calculated to fit this data. The resultant regression line is then extrapolated to 50 years (438,000 hours). The method of calculation is an internationally accepted procedure described in ISO/TR 9080. The required values of stress and time are specified in ISO 4427. The internationally accepted method for calculating circumferential hoop stress is derived from Barlow's formula and is as follows:

$$\sigma = p(d - e)/2e$$

where:

p = internal pressure (MPa)

e = minimum wall thickness (mm)

d = mean external diameter (mm)

σ = circumferential hoop stress in wall of pipe (MPa)

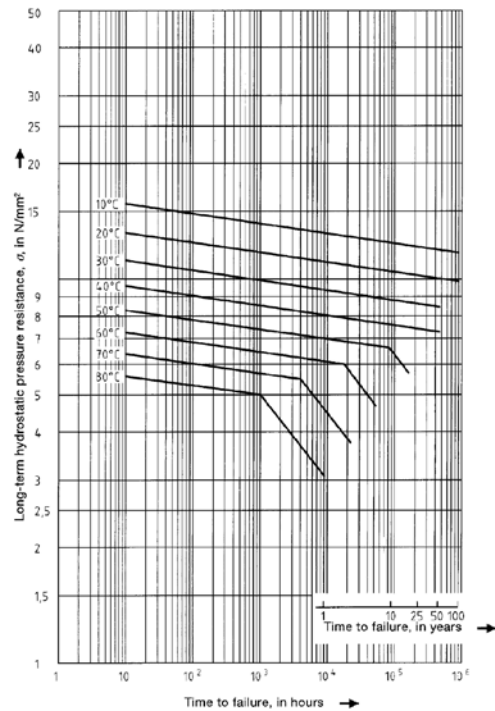

Figure 3: Long-term hydrostatic pressure resistance of pipes made from PE 100

The Stress Regression Line for HDPE is given below. In piping construction, PE is mostly used for buried gas and water lines. For this range of applications, polyethylene has become the dominant material in numerous countries. But also building technology and industrial piping installations make use of the advantages of this material.

The advantages include:

- Low weight
- Outstanding flexibility
- Good abrasion resistance
- Corrosion resistance
- High impact resistance even at very low temperatures
- Good chemical resistance
- Safe and easy jointing by welding
- Excellent cost-performance ratio

Mechanical properties

Modern PE100 grades show a bimodal molecular weight distribution, i. e. they consist of two different kinds of molecular chains (short and long). These polyethylenes combine a high tensile strength with a high resistance against fast and slow crack propaga-

Introduction to plastics

tion. In addition, the short molecular chains provide a good processability.

Similar to ABS, PE also shows very high impact strength, even at low temperatures. For this test, a specimen is weakened with a sharp notch and then struck. In doing this the impact energy absorbed by the material is measured. This test proves that polyethylene is insensitive to surface damage with subsequent impact stress. A robust behavior like this, combined with a high elongation to break, is of big advantage in a lot of applications, e.g. in regions that have a high risk of earthquakes.

The long-term behavior for internal pressure resistance is provided by the hydrostatic strength curve based on the EN ISO 15494 standard (see the Calculation and Long-Term Behavior section for PE). The application limits for pipes and fittings, as shown in the pressure-temperature diagram, can be derived from these curves.

Chemical, weathering, and abrasion resistance

Due to its non-polar nature as a hydrocarbon of high molecular weight, polyethylene shows a high resistance against chemical attack. PE is resistant to acids, alkaline solutions, solvents, alcohol and water. Fat and oil swell PE slightly. PE is not resistant against oxidizing acids, ketones, aromatic hydrocarbons and chlorinated hydrocarbons.

For detailed information, please refer to the detailed list of chemical resistance in In table 1.

If polyethylene is exposed to direct sunlight over a long period of time, it will, like most natural and plastic materials, be damaged by the short wave UV portion of sunlight together with oxygen in the air, causing photo-oxidation. Because of this, our black polyethylene grades are effectively stabilized against UV light by adding carbon black. As with ABS, PE also has excellent resistance against abrasion. As a result, PE piping systems are used in numerous applications for transporting solids and slurries.

Experience has shown that PE as well as ABS offers considerable advantages over metal and other plastics for many such applications.

/ = Specimen has limited swelling 3-8% or alternatively weight resistance only loss 0.5-5% and/or elongation at break decreased by <50%

- = Specimen is not resistant swelling >8% or alternatively weight loss >5% and/or elongation a break decreased by >50%

D = discoloration

* = or at the boil

+ = Specimen is resistant swelling <3% or alternatively weight loss <0.5%, elongation of break not significantly changed

Substance	Polyethylene		
	Concentration	68°F	140°F
Acetic acid	100%	+	/D
Acetic acid, Aqueous	70%	+	+
Acetylene		+	
Alcohol		+	
Amino acids		+	+
Ammonium chloride, aqueous	all	+	+
Animal oils		+	/
Arsenic acid, aqueous	all	+	+
Benzoic acid, aqueous	all	+	+
Bromic acid	Conc.	-	
Butane, Gaseous		+	
Calcium hydroxide		+	+
Carbolic acid		+	+D
Carbon dioxide	100%	+	+
Chloral hydrate, aqueous	all	+	+D
Chloroacetic acid, aqueous	all	+	+
Chloroform	Tech. pure	/to-	-
Citric acid, aqueous	saturated	+	+
Ethanol	96%	+	+
Ethyl alcohol	96%	+	+
Ethyl ether	Tech. pure	+to/	/*
Ethylene oxide, gaseous	Tech. pure	+	+
Ferric chloride, aqueous	all	+	+
Formic acid, aqueous	85%	+	+
Fuel oil		+	/
Glycolic acid, aqueous	Up to 70%	+	+
Liquid paraffin		+	+
Machine oil		+	/
Malic acid, aqueous	50%	+	+
Methanol	Tech. pure	+	+
Methyl alcohol		+	+
Milk		+	+
Naphtha		+	/
Oxygen	all	+	+
Petrol	Tech. pure	+	+to/
Phosphoric acid, aqueous	80%..95%	+	/D
Polyglycols		+	+
Propanol		+	+
Pyridine		+	/
Sodium chlorate, aqueous	saturated	+	+
Sodium hydroxide, aqueous	all	+	+
Sulphuric acid, aqueous	Up to 50%	+	+
Sulphuric acid, aqueous	70%	+	+
Sulphuric acid, aqueous	80%	+	+
Sulphuric acid, aqueous	98%	/	-
Uric acid		+	+
Waxes		+	+to/

Table 1: Chemical Resistant

Introduction to plastics

Thermal properties

Polyethylene pipes can be used at temperatures ranging from $-50\text{ }^{\circ}\text{C}$ to $+60\text{ }^{\circ}\text{C}$.

At higher temperatures, the tensile strength and stiffness of the material are reduced. Therefore, please consult the pressure-temperature diagram. For temperatures below $0\text{ }^{\circ}\text{C}$ it must be ensured, as for every other material that the medium does not freeze, consequently damaging the piping system.

Like all thermoplastics, PE shows a higher thermal expansion than metal. Our PE has a coefficient of linear thermal expansion of 0.15 to 0.20 mm/m K, which is 1.5 times greater than that of e. g. PVC. As long as this is taken into account during the planning of the installation, there should be no problems in this regard.

The thermal conductivity is 0.38 W/m K. Because of the resulting insulation properties, a PE piping system is notably more economical in comparison to a system made of a metal like copper.

Combustion behavior

Polyethylene belongs to the flammable plastics. The oxygen index amounts to 17 %. (Materials that burn with less than 21 % of oxygen in the air are considered to be flammable).

PE drips and continues to burn without soot after removing the flame. Basically, toxic substances are released by all burning processes. Carbon monoxide is generally the combustion product most dangerous to humans.

When PE burns, primarily carbon dioxide, carbon monoxide and water are formed.

The following classifications in accordance with different combustion standards are used: According to UL94, PE is classified as HB (Horizontal Burning) and according to DIN 53438-1 as K2. According to DIN 4102-1 and EN 13501-1, PE is listed as B2 (normally flammable). In the French classification of building materials, polyethylene corresponds to M3 (of average flammability rating).

The self-ignition temperature is $350\text{ }^{\circ}\text{C}$. Suitable fire-fighting agents are water, foam, carbon dioxide or powder.

Electrical properties

Because of the low water absorption of PE, its electrical properties are hardly affected by continuous water contact. Since PE is a non-polar hydrocarbon polymer, it is an outstanding insulator. These properties, however, can be worsened considerably as a result of pollution, effects of oxidizing media or weathering. The specific volume resistance is $>10^{17}\text{ }\Omega\cdot\text{cm}$; the dielectric strength is 220 kV/mm.

Because of the possible development of electrostatic charges, caution is recommended when using PE in applications where the danger of fires or explosion is given.

INSTALLATION

The trench

National and regional regulations and directives for soil covered pipelines are to be followed during the construction of the necessary trench. The trench has to allow all parts of the pipeline to be in a frost-safe depth.

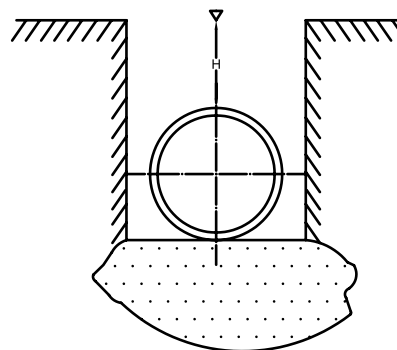

The base of the trench has to enable the pipeline to bear on smoothly. In case of bedrock the trench has to be excavated deeper and filled to the desired depth with appropriate material which grain size does not damage the pipe.

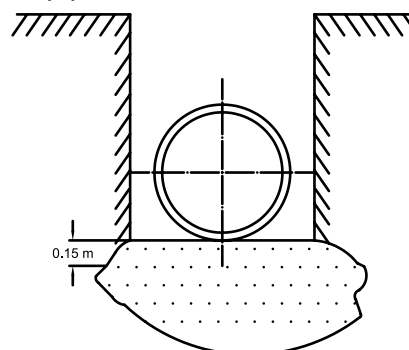

Introduction to plastics

The crucial factor to attain a good load capacity of pipes and fittings underground is a correct construction of the area around the pipe. The correct design of the pipe zone is determining the load capacity of PE pipes and fittings.

The pipe zone consists from bedding side fill and cover depth.

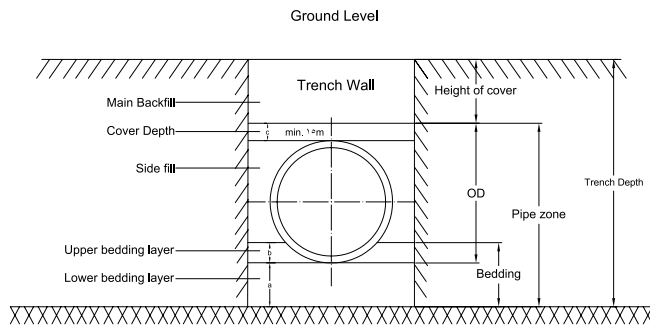

The pipe zone has to be designed according to flanging fundamentals and static calculation. The area between trench sole and side fill is referred to as bedding. By exchanging ground a load carrying bedding has to be created.

Usually, the minimum bedding is according to EN1610 a = 100mm, in case of bedrock or compacted underground a = 150mm. Further, there are demands concerning the filling material. Materials with elements bigger than:

- 22 mm at DN ≤ 200
- 40 mm at DN > 200 until DN ≤ 600

should not be used.

The upper bedding layer b is assessed from static calculations.

It is important to assure no cavities below the pipe. The bedding dissipates all loads from the pipe evenly into the ground. For this reason the PE pipe has to lay evenly on the bedding over its complete length.

The upper end of the pipe zone is defined according to EN 1610 as 150mm above the pipe apex respectively 100mm above the pipe connection. When filling and compacting the cover depth and the main backfill one has to make sure not to damage the pipe.

Long-term behavior of thermoplastic material

The most important characteristic of pressurized

plastics is the pressure-time-behavior. This means the empirical and calculated life-time of pipes and parts of piping systems under depending boundary conditions such as inner pressure, temperature and time. The allowable stresses are always to be regarded dependent in contrast to metallic parts. By increasing the temperature during testing it becomes possible to conclude on longtime- behavior at 20°C based on short-term tests.

The following picture shows the long-term behavior of PE 100 according to EN ISO 15494:2003.

Calculation of allowed pressure/wall thickness

The technical design of pressurized thermoplastic pipes is carried out strictly according to strength requirements by means of the kesselformula. All pipe dimensions in standards are based on this formula. Deviations are just possible in smaller diameters since certain wall thicknesses will not under-run be due to practical and production limitations.

Using:

$$e = \frac{P d}{20 \sigma_{zul} + P}$$

e: wall thickness in mm

d: outer pipe diameter in mm

p: allowable pressure in bar

σ_{zul} : allowable stress in N/mm²

Simply using the nominal pressure is not enough anymore. The usual deployment of PN as a measure for the pipe size can harbour a danger of confusion regarding butt fusion. Plastic pipes and fittings equally pressure tolerable are meanwhile marked pressure-neutrally. The goal is to prevent a misuse of pipes in different application areas or different conditions. According to ISO 4065 pipes are classified into series. The series determines the load resistance without possibility of confusion as the nominal pressure did.

The pipe series is marked by the letter S. This series is based on the following formula:

$$S = \frac{10 \sigma_{zul}}{P C} = \frac{d - e}{2 e}$$

Introduction to plastics

Consequently, S is dimensionless. For an PE-pipe with the dimensions 110 × 10 mm the formula yields

$$S = 5 = (110 - 10) / (2 * 10).$$

Further the denotation SDR is known. SDR stands for Standard Dimension Ratio. SDR indicates the diameter/wall-thickness-ratio.

$$SDR = \frac{d}{e}$$

Series- and SDR are connected through the following formula:
 $SDR = 2 \times S + 1$ or $S = (SDR - 1) / 2$.
 Using the upper example:

$$SDR = \frac{110}{10} = 11 = 2 \times 5 + 1$$

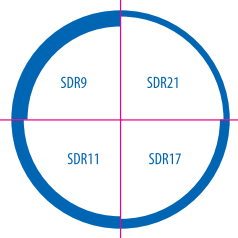

Currently all three indicators PN, S and SDR are used in the market. Takab Ettasal recommends to always stating dimension, wall-thickness and pipe series or SDR.

SDR	Pipe series S	Nominal Pressure PN
$SDR = d / e$ $= 2 S + 1$	$S = \frac{d - e}{2 e}$	$PN = \frac{10 \sigma_s}{S}$
e.g.: SDR of 110/10 = 11	$S = \frac{100 - 10}{2 \times 10} = 5$	$PN = \frac{20 \sigma_s}{SDR - 1}$ <small>$\sigma_s =$ Designed stress</small>

Required pipe diameter

What size should the pipe be?

Formulas

The following formula can be used for a first approximation of the pipe size required for a given flow rate:

$$d_i = 18.8 \sqrt{\frac{Q_1}{V}} \quad OR \quad d_i = 35.7 \sqrt{\frac{Q_2}{V}}$$

where:

d_i inside pipe diameter in mm

Q_1 flow rate in m^3/h

Q_2 flow rate in l/s

18.8 conversion factor for units

35.7 conversion factor for units

v flow velocity in m/s

The flow velocity must first be approximated according to the intended use of the pipeline. Standard values for the flow velocity are:

Liquids

$v = 0.5 - 1.0$ m/s for suction

$v = 1.0 - 3.0$ m/s for delivery

Gases

$v = 10 - 30$ m/s

The calculations of pipe diameter have not taken into account hydraulic losses. These require special calculations for which we offer the following information and recommendations.

Pipe / Fittings dimensions:

Dimensions in millimeter

Nominal Size DN/OD	Nominal outside diameter dn	Mean outside diameter		Max out-of-roundness for straight pipes
		$d_{em,min}$	$d_{em,max}$	
16	16	16,0	16,3	1,2
20	20	20,0	20,3	1,2
25	25	25,0	25,3	1,2
32	32	32,0	32,3	1,3
40	40	40,0	40,4	1,4
50	50	50,0	50,4	1,4
63	63	63,0	63,4	1,5
75	75	75,0	75,5	1,6
90	90	90,0	90,6	1,8
110	110	110,0	110,7	2,2
125	125	125,0	125,8	2,5
140	140	140,0	140,9	2,8
160	160	160,0	161,0	3,2
180	180	180,0	181,1	3,6
200	200	200,0	201,2	4,0
225	225	225,0	226,4	4,5
250	250	250,0	251,5	5,0
280	280	280,0	281,7	9,8
315	315	315,0	316,9	11,1
355	355	355,0	357,2	12,5
400	400	400,0	402,4	14,0
450	450	450,0	452,7	15,6
500	500	500,0	503,0	17,5
560	560	560,0	563,4	19,6
630	630	630,0	633,8	22,1

Introduction to plastics

Wall thickness and their tolerances

PIPE SERIES														Dimensions in millimeter		
SDR 7.4		SDR 9		SDR 11		SDR 13.6		SDR 17		SDR 21		SDR 26				
S 3.2		S 4.0		S 5		S 6.3		S 8		S 10		S 12.5				
Nominal Pressure (PN) ^a bar																
PE 100	PN 25		PN 20		PN 16		PN 12.5		PN 10		PN 8		PN 6 ^c			
Nominal Size	Wall thickness ^b (mm)															
	e _{min}	e _{max}	e _{min}	e _{max}	e _{min}	e _{max}	e _{min}	e _{max}	e _{min}	e _{max}	e _{min}	e _{max}	e _{min}	e _{max}	e _{min}	e _{max}
16	2.3 ^c	2.7	2.0 ^c	2.3	-	-	-	-	-	-	-	-	-	-	-	-
20	3.0	3.4	2.3 ^c	2.7	2.0 ^c	2.3	-	-	-	-	-	-	-	-	-	-
25	3.5	4.0	3.0	3.4	2.3 ^c	2.7	2.0 ^c	2.3	-	-	-	-	-	-	-	-
32	4.4	5.0	3.6	4.1	3.0	3.4	2.4	2.8	2.0 ^c	2.3	-	-	-	-	-	-
40	5.5	6.2	4.5	5.1	3.7	4.2	3.0	3.5	2.4	2.8	2.0 ^c	2.3	-	-	-	-
50	6.9	7.7	5.6	6.3	4.6	5.2	3.7	4.2	3.0	3.4	2.4	2.8	2.0	2.3	-	-
63	8.6	9.6	7.1	8.0	5.8	6.5	4.7	5.3	3.8	4.3	3.0	3.4	2.5	2.9	-	-
75	10.3	11.5	8.4	9.4	6.8	7.6	5.6	6.3	4.5	5.1	3.6	4.1	2.9	3.3	-	-
90	12.3	13.7	10.1	11.3	8.2	9.2	6.7	7.5	5.4	6.1	4.3	4.9	3.5	4.0	-	-
110	15.1	16.8	12.3	13.7	10.0	11.1	8.1	9.1	6.6	7.4	5.3	6.0	4.2	4.8	-	-
125	17.1	19.0	14.0	15.6	11.4	12.7	9.2	10.3	7.4	8.3	6.0	6.7	4.8	5.4	-	-
140	19.2	21.3	15.7	17.4	12.7	14.1	10.3	11.5	8.3	9.3	6.7	7.5	5.4	6.1	-	-
160	21.9	24.2	17.9	19.8	14.6	16.2	11.8	13.1	9.5	10.6	7.7	8.6	6.2	7.0	-	-
180	24.6	27.2	20.1	22.3	16.4	18.2	13.3	14.8	10.7	11.9	8.6	9.6	6.9	7.7	-	-
200	27.4	30.3	22.4	24.8	18.2	20.2	14.7	16.3	11.9	13.2	9.6	10.7	7.7	8.6	-	-
225	30.8	34.0	25.2	27.9	20.5	22.7	16.6	18.4	13.4	14.9	10.8	12.0	8.6	9.6	-	-
250	34.2	37.8	27.9	30.8	22.7	25.1	18.4	20.4	14.8	16.4	11.9	13.2	9.6	10.7	-	-
280	38.3	42.3	31.3	34.6	25.4	28.1	20.6	22.8	16.6	18.4	13.4	14.9	10.7	11.9	-	-
315	43.1	47.6	35.2	38.9	28.6	31.6	23.2	25.7	18.7	20.7	15.0	16.6	12.1	13.5	-	-
355	48.5	53.5	39.7	43.8	32.2	35.6	26.1	28.9	21.1	23.4	16.9	18.7	13.6	15.1	-	-
400	54.7	60.3	44.7	49.3	36.3	40.1	29.4	32.5	23.7	26.2	19.1	21.2	15.3	17.0	-	-
450	61.5	67.8	50.3	55.5	40.9	45.1	33.1	36.6	26.7	29.5	21.5	23.8	17.2	19.1	-	-
500	-	-	55.8	61.5	45.4	50.1	36.8	40.6	29.7	32.8	23.9	26.4	19.1	21.2	-	-
560	-	-	62.5	68.9	50.8	56.0	41.2	45.5	33.2	36.7	26.7	29.5	21.4	23.7	-	-
630	-	-	70.3	77.5	57.2	63.1	46.3	51.1	37.4	41.3	30.0	33.1	24.1	26.7	-	-

^aPN values are based on SF=1,25

^bTolerance in accordance with ISO 11922-1:1997, grade V, calculated from $(1.5 e_{min} + 0,1)$ mm rounded up to the next 0,1 mm, for certain applications for $e > 30$ mm, ISO 11922-1:1997, grade T, tolerance may be used calculated from $0,15 e_{min}$ rounded up to the next 0,1 mm.

^cThe calculated value of e_{min} according to ISO 4065 is rounded up to the nearest value of the either 2,0, 2,3 or 3,0. This is to satisfy certain national requirements. For practical reasons, a wall thickness of 3,0 is recommended for electrofusion jointing and lining application.

According to standard

✓EN 12201

✓ISO 4427

✓INSO 14427

Allowable working pressure of PE pipe lines for water supply

Allowable working pressure of PE pipe lines for water supply

Temperature (°C)	Operating Period (years)	Diameter – wall thickness relation SDR						
		41	33	26	17	11	7.4	6
		Pipe series S						
		20	16	12.5	8	5	3.2	2.5
		PN						
		4	5	6.3	10	16	25	32
Permissible component operating pressure ps (bar)								
10	5	5.0	6.3	7.9	12.6	20.2	31.5	40.4
	10	4.9	6.2	7.8	12.4	19.8	31.0	39.7
	25	4.8	6.0	7.6	12.1	19.3	30.2	38.7
	50	4.7	5.9	7.5	11.9	19.0	29.7	38.0
	100	4.6	5.8	7.3	11.6	18.7	29.2	37.4
20	5	4.2	5.3	6.6	10.6	16.9	26.5	33.9
	10	4.1	5.2	6.5	10.4	16.6	26.0	33.3
	25	4.0	5.0	6.4	10.1	16.2	25.4	32.5
	50	4.0	5.0	6.3	10.0	16.0	25.0	32.0
	100	3.9	4.9	6.1	9.8	15.7	24.5	31.4
30	5	3.6	4.5	5.6	9.0	14.4	22.5	28.8
	10	3.5	4.4	5.5	8.8	14.1	22.1	28.3
	25	3.4	4.3	5.4	8.6	13.8	21.6	27.6
	50	3.3	4.2	5.3	8.4	13.5	21.2	27.1
	100	3.2	4.1	5.2	8.2	13.2	20.8	26.6
40	5	3.0	3.8	4.8	7.7	12.3	19.3	24.7
	10	3.0	3.8	4.7	7.6	12.1	19.0	24.3
	25	2.9	3.7	4.6	7.4	11.8	18.5	23.7
	50	2.9	3.6	4.5	7.2	11.6	18.2	23.3
	100	2.8	3.5	4.4	7.0	11.3	17.8	22.8
50	5	2.6	3.3	4.2	6.7	10.7	16.7	24.4
	10	2.6	3.2	4.0	6.5	10.4	16.2	20.3
	15	2.3	2.9	3.7	5.9	9.5	14.8	19.0
60	5	1.9	2.4	3.0	4.8	7.7	12.1	15.5
70	2	1.5	1.9	2.4	3.9	6.2	9.8	12.5

Installation methods

1-Electrofusion welding



1- Measure area which has to be scraped with marker.



2- Scrape at last 0.2 mm of outside pipe surface to remove oxidation and other contaminants.



3-Clean pipe scraped area .
Note: do not touch the scraped area with bare hands after scraping and cleaning.



4- Insert pipe into electrofusion coupler.



5- Place second pipe end up to first pipe, push electrofusion coupler back onto the second pipe until the second marking area with bare hands after scraping and cleaning.



6- Read barcode by scanner or light pen.

2-Butt fusion welding



1-Place the pipes or fittings in the clamps .



2-Check alignment.

Installation methods

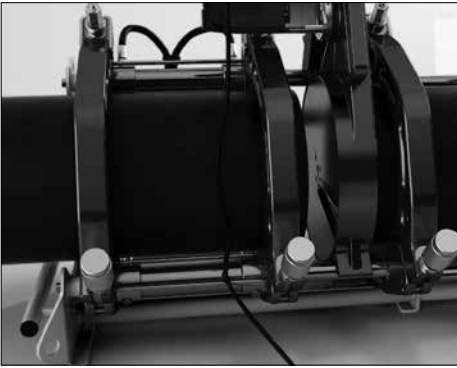

3-Place facing tool and start to cut surface or both pipes or fittings end .

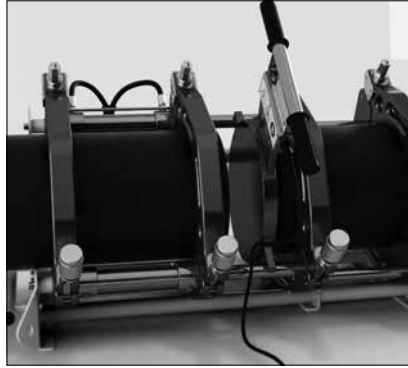

4-Place heater plate and apply pressure determined until a uniform bead formed on each end .

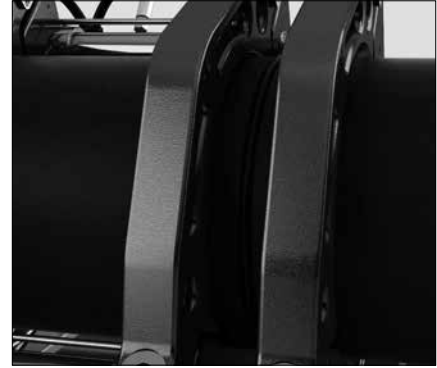

5-Remove heater plate, close clamps to bring bead up .

3-Flanged Joint



Type (A): Flange with steel Backing Ring



Type (B): Steel Core Hole Flange

Advantage of Steel Core Hole Flange:

- 1- High Strength in comparing with backing ring due to using special material
- 2- No need to galvanized backing ring due to coating with polyethylene
- 3- Using shorter bolts in comparing with butt fusion polyethylene flange
- 4- Easy performance projects due to weigh less and reduction implementation time
- 5- Reduction of project cost
- 6- Uniform stress distribution

Welding techniques:

1-Butt Welding

Butt-fusion jointing is a thermo-fusion process which involves the simultaneous heating of the ends of two Components which are to be joined until a melt state is attained on each contact surface. The two surfaces are then brought together under controlled pressure for a specific cooling time and homogeneous fusion is formed upon cooling. The resultant joint is resistant to end thrust and has comparable performance under pressure to the pipe.

This method of jointing requires an electrically heated plate to raise the temperature of the pipe ends to the required fusion temperature and is used for PE 80 and PE 100 grades of material for pipe of size 32 mm and above of the same Standard Dimension Ratio (SDR).

Remarks:

- 1) Dissimilar materials and dissimilar wall thicknesses can be joined by electrofusion. (Please note that the maximum working pressure should not exceed the lower of the two pipes.)
- 2) Similar material and/or wall thickness may be joined by Butt fusion or electrofusion. (Please note that SDR17 can be butt fused To SDR17.6)
- 3) Dissimilar wall thickness must not be joined by butt fusion.

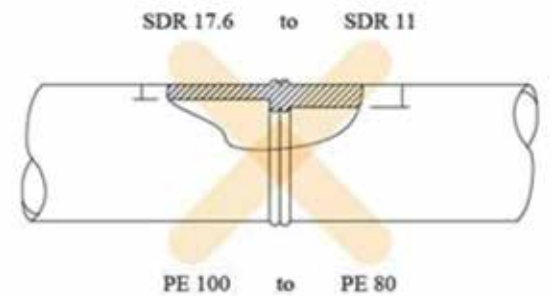
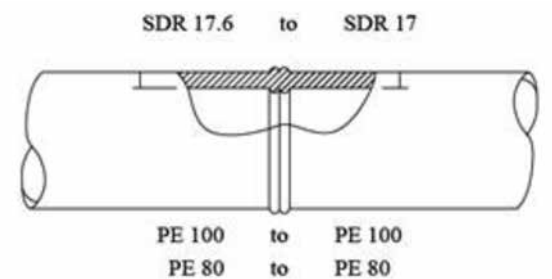
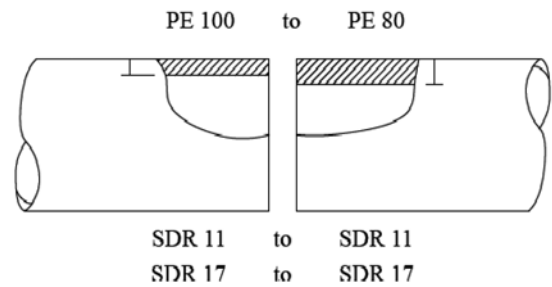

2- Electrofusion welding

The sectional drawings show the jointing sequence from energizing the coil until completion of fusion. The whole cycle is electronically monitored by the electrofusion control unit (ECU).

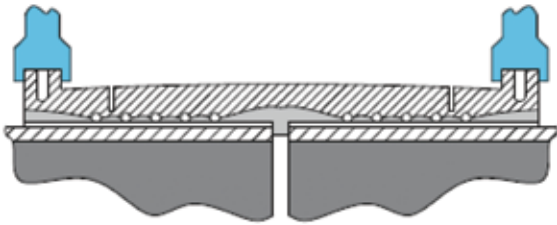

1. Pipe positioned in coupler prior to energising coil.

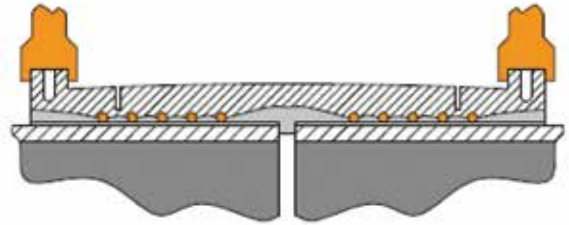

2. Coil energised.

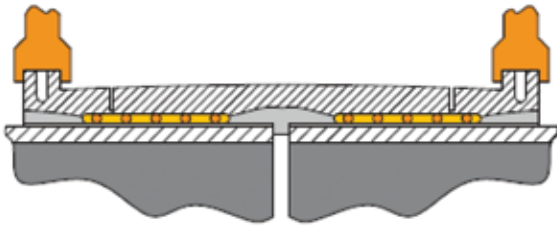

3. Material surrounding coil starts to melt.

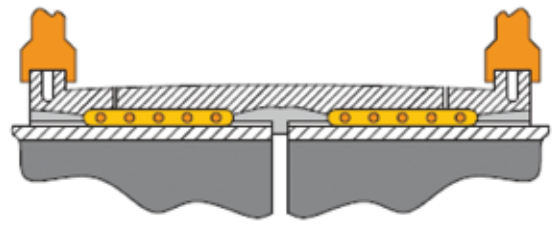

4. Area of melt extends leading to expansion towards pipe surface.

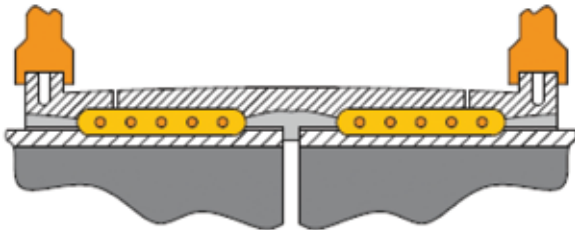

5. Heat transfers to pipe wall and material starts to melt

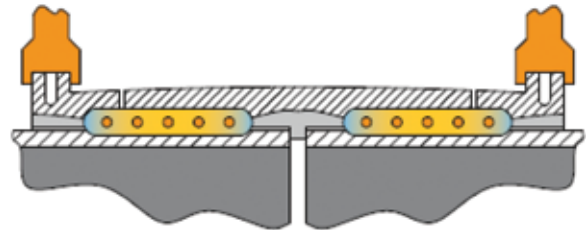

6. Melt solidifies at the start of the cold zones, thereby sealing the melt zone. Further input of energy causes increase in melt pressure.

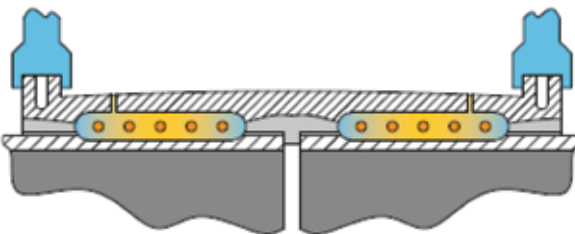

7. Melt pressure reaches optimum value at end of energising cycle. Emergence of the melt at the indicator holes shows that fusion is complete.

Reference Project



HYDRO polymer

Hydropolymer GmbH

Betzdorfer Straße 8 57520 Schutzbach /Germany

Phone: +49 (0) 2741 976461
emailto: info@hydropolymer.net

Fax: +49 (0) 274197649261
internet: www.hydropolymer.net

HYDRO polymer

Hydropolymer GmbH

Betzdorfer Straße 8 57520 Schutzbach /Germany

Phone: +49 (0) 2741 976461
emailto: info@hydropolymer.net

Fax: +49 (0) 274197649261
internet: www.hydropolymer.net